

Paving the Way to Net-Zero Ready New Homes

U.S. DEPARTMENT OF
ENERGY

Energy Efficiency &
Renewable Energy



What DOE Challenge Home Specifications Define Truly Zero Net-Energy Ready Performance?

Jamie Lyons, P.E
DOE Challenge Home



U.S. DEPARTMENT OF ENERGY
**CHALLENGE
HOME**

A Symbol of Excellence

Comfort



Indoor Environment



Durability



Advanced Technology



Construction Quality



Energy Efficiency



KEY

- DOE Challenge Home
- ENERGY STAR Home
- Existing Home

This label indicates relative performance of this DOE Challenge Home to existing homes (built between 1990 and 2010) and ENERGY STAR qualified homes. Actual performance may vary.

U.S. DEPARTMENT OF **ENERGY** | Energy Efficiency & Renewable Energy

1. How is DOE Challenge Home defining ZERO Net-Energy Ready?

2. What are the DOE Challenge Home specifications?
 - Emphasis: Delta with ENERGY STAR
 - Also Covered: Encouraged Components

- Critical – but not in this session
 - a. Business Case
 - b. Consumer Value Propositions

- Zero Net-Energy Ready – Made Simple
- DOE Challenge Home Specs – Overview
- DOE Challenge Home Best Practices
 - Ducts in Conditioned Space
 - Super Air-Tight Construction
 - 2012 IECC Insulation
 - Super Windows
 - Efficient Low-Load HVAC
 - Efficient Components
- Indoor Air Quality
- Solar Ready
- Water Conservation
- Disaster Resistance
- Quality Management

Zero Net-Energy Ready Homes **Made Simple**

Step #1:

Ensure Comprehensive Building Science by making ENERGY STAR v3 a prerequisite.



Step #2:

Add proven technologies and practices

from Building America which, along with complete building science, lock in Zero Net-Energy capability.



Step #3:

Include energy efficient components
throughout the home
to complement high-performance enclosure.



Step #4:

Provide comprehensive pollutant control

critical in homes this tight and well-insulated
(specify EPA Indoor airPLUS requirements).

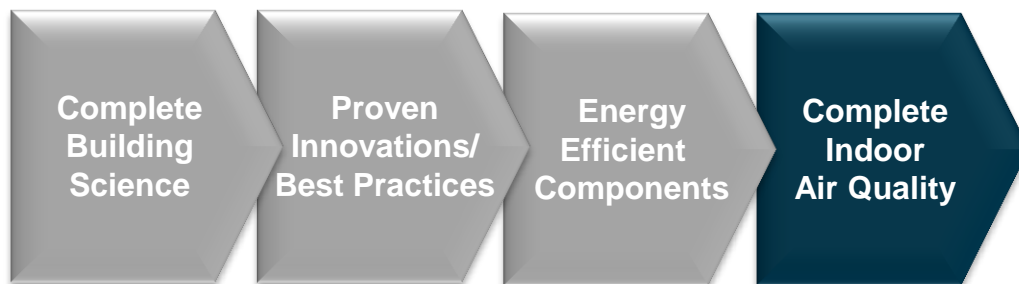

Step #5:

Ensure low-cost details that can save \$1,000's downstream to install solar
since homes are ready for zero net-energy performance.

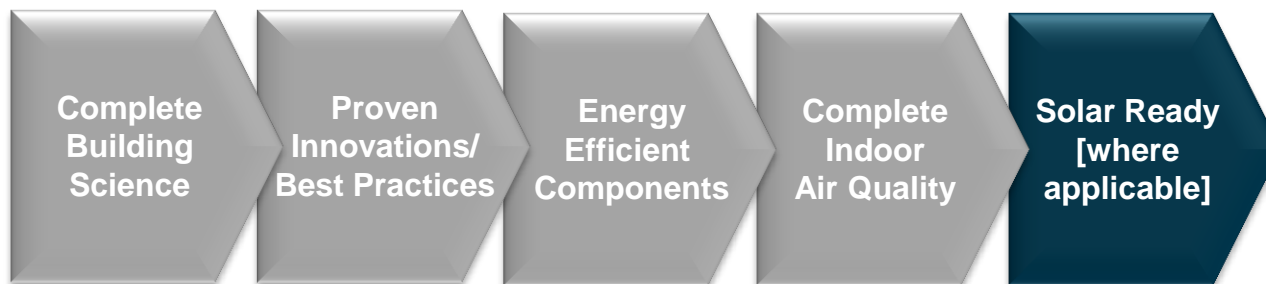

Step #6:

Start addressing related water efficiency issues
in homes this environmentally responsive
(recommend EPA WaterSense specifications).

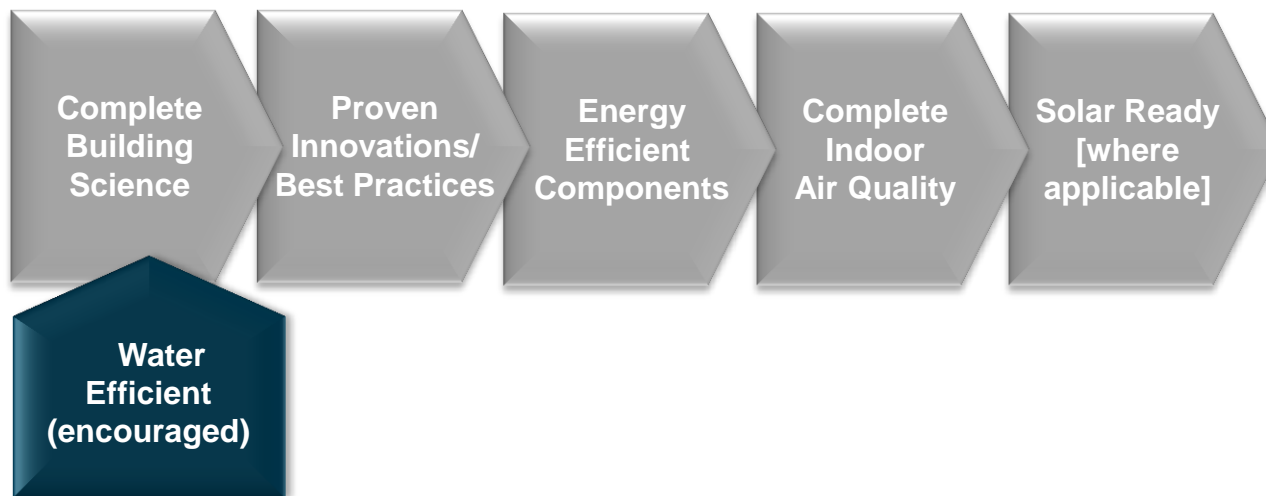

Step #7:

Don't ignore disaster resistance

since homes built this well should last 100's of years
(recommend IBHS Fortified Homes specifications).

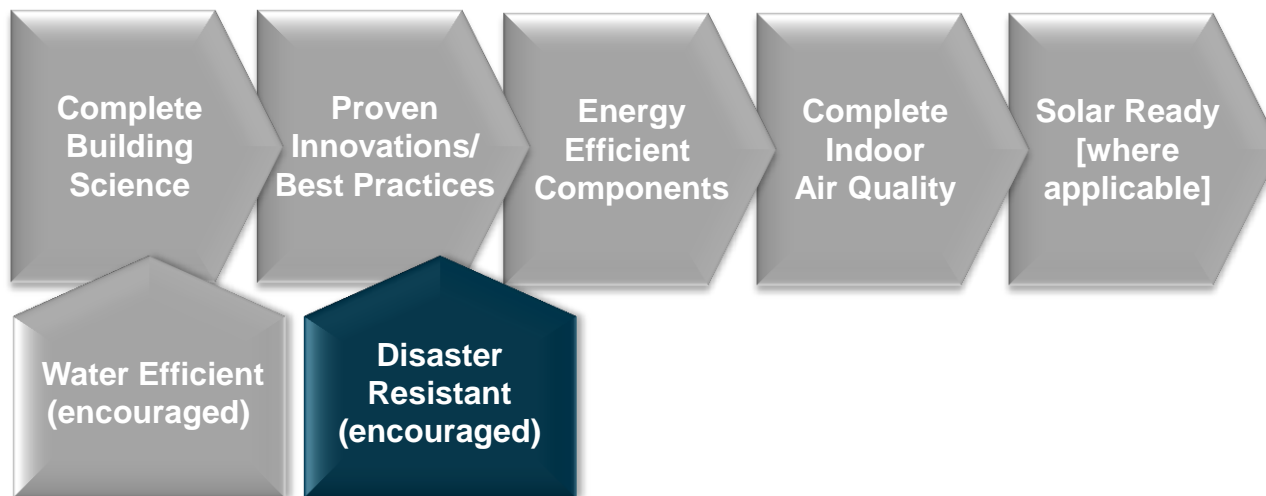

Step #8:

Encourage QA/QC practices

to help ensure the success of builder partners.



Summary:

All the pieces add up to DOE Challenge Home...



Summary:

**...and now home is ready for renewable power.
This is a Zero Net-Energy Ready Home.**



Zero Net-Energy Ready

Technical Specifications: Best Practices

- Ducts in Conditioned Space
- Super Air-Tight Construction
- 2012 IECC Insulation
- Super Windows
- Ultra-Efficient Low-Load HVAC

Zero Net-Energy Ready

Technical Specifications: Best Practices Ducts in Conditioned Spaces

- Ductwork thermal losses can range from 10-45%
- Supply/return duct grills add extensive penetrations into unconditioned space
- In addition to thermal penalties:
 - IAQ
 - Comfort
 - Durability

- **Short Duct Run**

up to 10' of total length is permitted to be outside of the home's thermal and air barrier boundary.

- **Jump Ducts**

which do not directly deliver conditioned air from the HVAC unit may be located in attics if all joints, including boot-to-drywall, are fully air sealed with mastic

- **Ductless HVAC system**

- **Conditioned Floor Space**
within the thermal boundary
- **Unvented Attic**
regardless of whether conditioned with a supply register
- **Unvented Crawl Space/Basement**
which is within the home's thermal boundary
- **Vented Attic**
equivalent option where other locations in conditioned space are impractical, expensive, don't work well in specific climates, or increase envelope loads

Ducts in Conditioned Floor Space

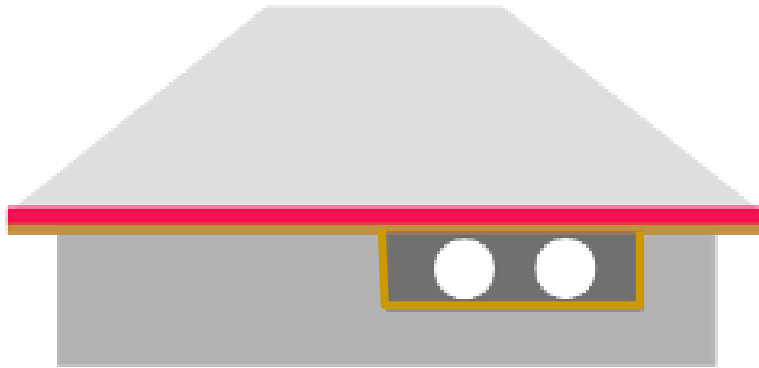

Ducts in dropped ceiling

 Insulation

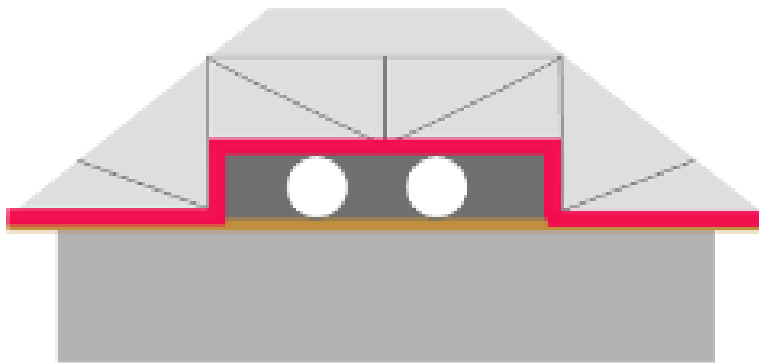

Ducts in modified truss
in attic

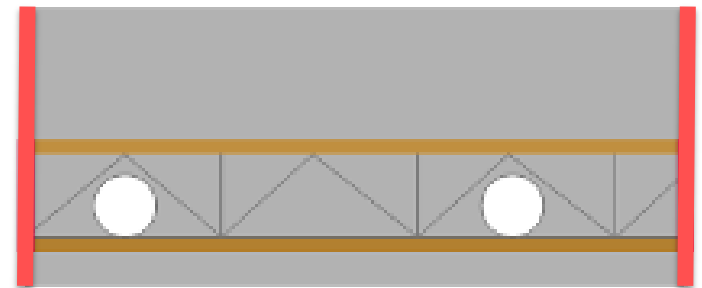

Ducts between floors

Ducts in Dropped Soffit



- Requires high-level of architectural integration
- Low-cost in simple plans
- Longer “throws” may be required based on plan

Dropped Soffit Requires Air Barrier – All Sides

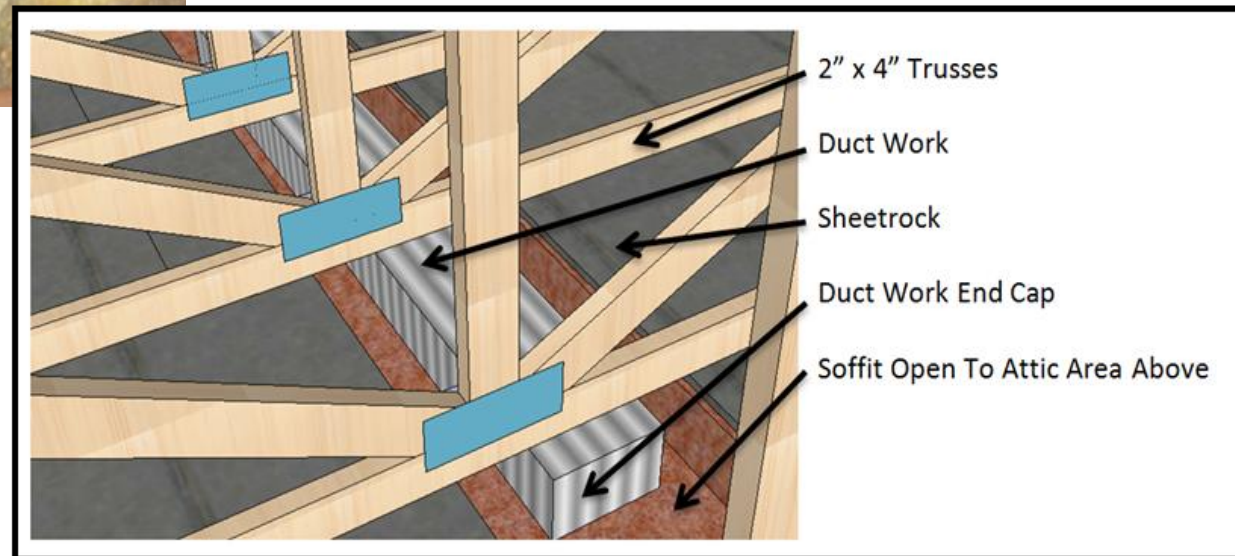

Ducts in Modified Truss

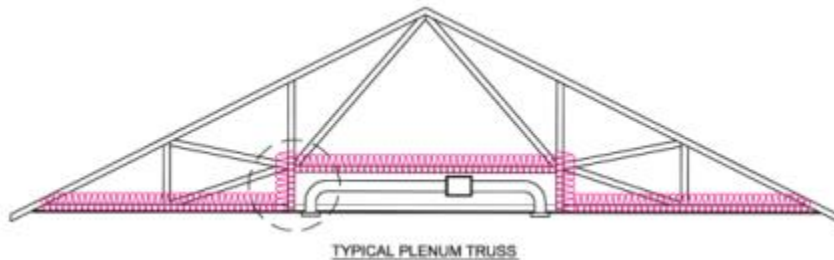

- Works well in narrow plans
- Moderate cost-increase
- Sealing the air-barrier is critical
- design integration required

Floor Truss Integrated Ducts



- Offers simple installation and design flexibility
- Very cost-effective
- Conducive to floor registers (which don't work well for cooling)
- High wall registers increase performance (for cooling), but also cost and complexity

IRC Section R806.5

- No interior Class 1 vapor retarder on ceiling
- CZ 5-8: Air impermeable insulation shall be Class II vapor retarder or have Class III vapor retarder in direct contact



402.2.1.1 Unvented Attic Assemblies

AIR-IMPERMEABLE: In direct contact with the underside of the sheathing

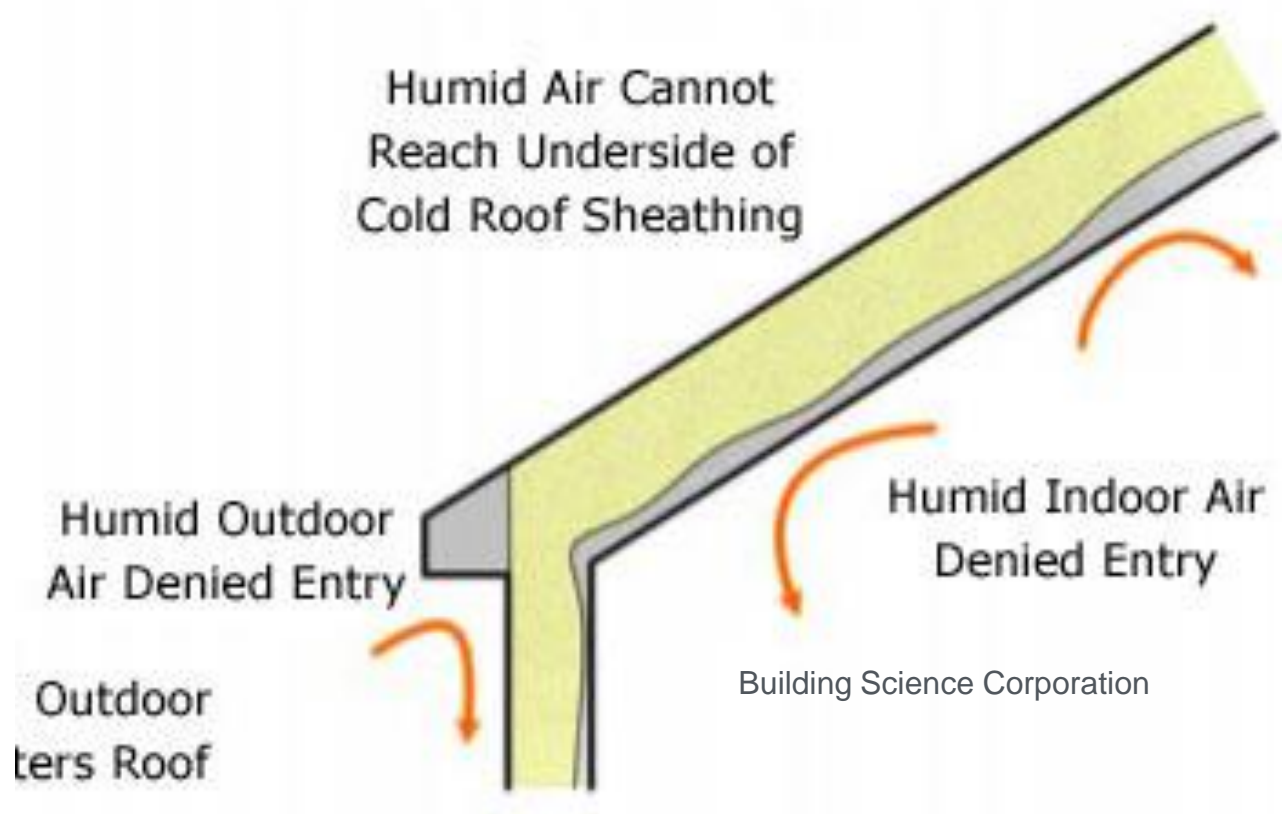

Unvented Attic Assemblies

AIR-IMPERMEABLE: In direct contact with the underside of the sheathing

AIR-PERMEABLE (e.g. – fiberglass or cellulose)

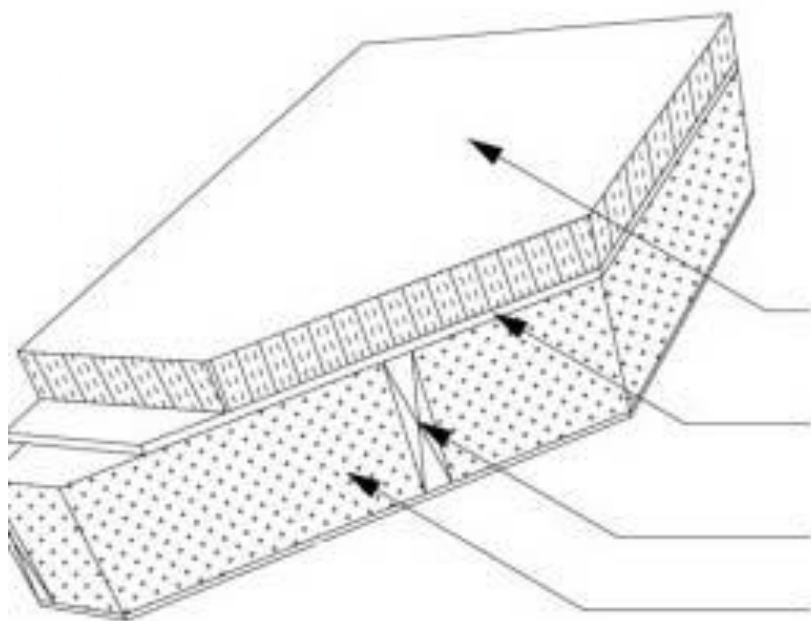

Rigid foam (Impermeable) ABOVE
THE ROOF SHEATHING

Roof Sheathing

Rafter

Cavity Insulation (Can be Air-Permeable)

Building Science Corporation

Minimum R-value of impermeable insulation

Climate Zone	Minimum Impermeable Insulation R-Value*	2012 IECC Ceiling R-Values
2B and 3B Tile Roof	None Required	30
1, 2A, 2B, 3A, 3B, 3C	R-5	38
4C	R-10	38
4A, 4B	R-15	49
5	R-20	49
6	R-25	49
7	R-30	49
8	R-35	49

*contributes but doesn't supersede 2012 IECC insulation requirements

Ducts in Unvented Crawl Space/ Basement

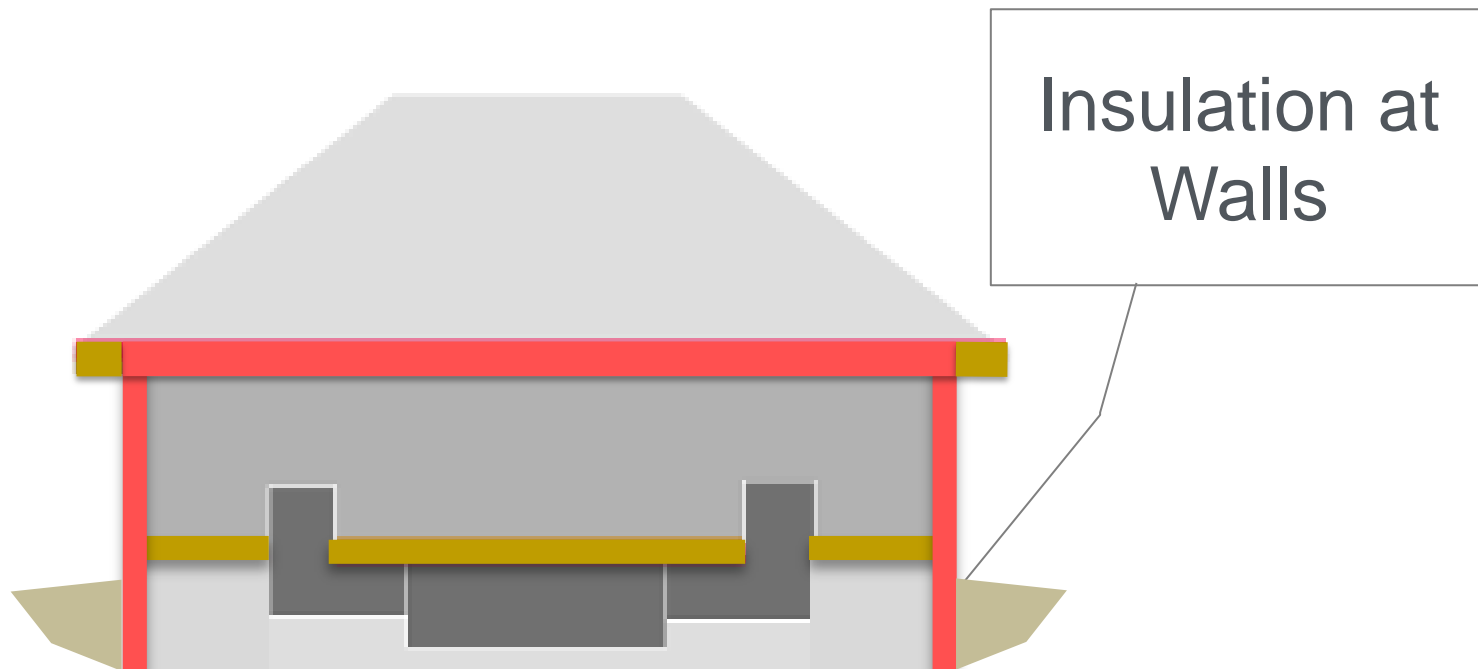

Insulation at
Walls

Ducts in unvented crawl space
or basement

- R-8 duct insulation minimum
- 1.5" minimum of ccSPF encapsulating ducts
- Ductwork buried min. 2" blown-in insulation
- Total duct leakage ≤ 3 CFM25 per 100 ft² CFA

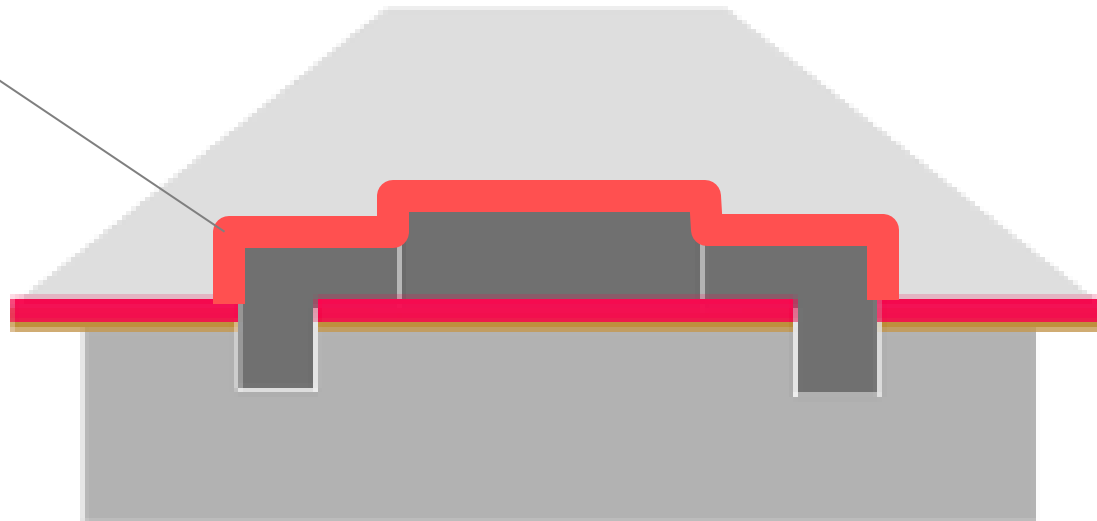

Ducts in vented attic

Buried Encapsulated Duct Implementation

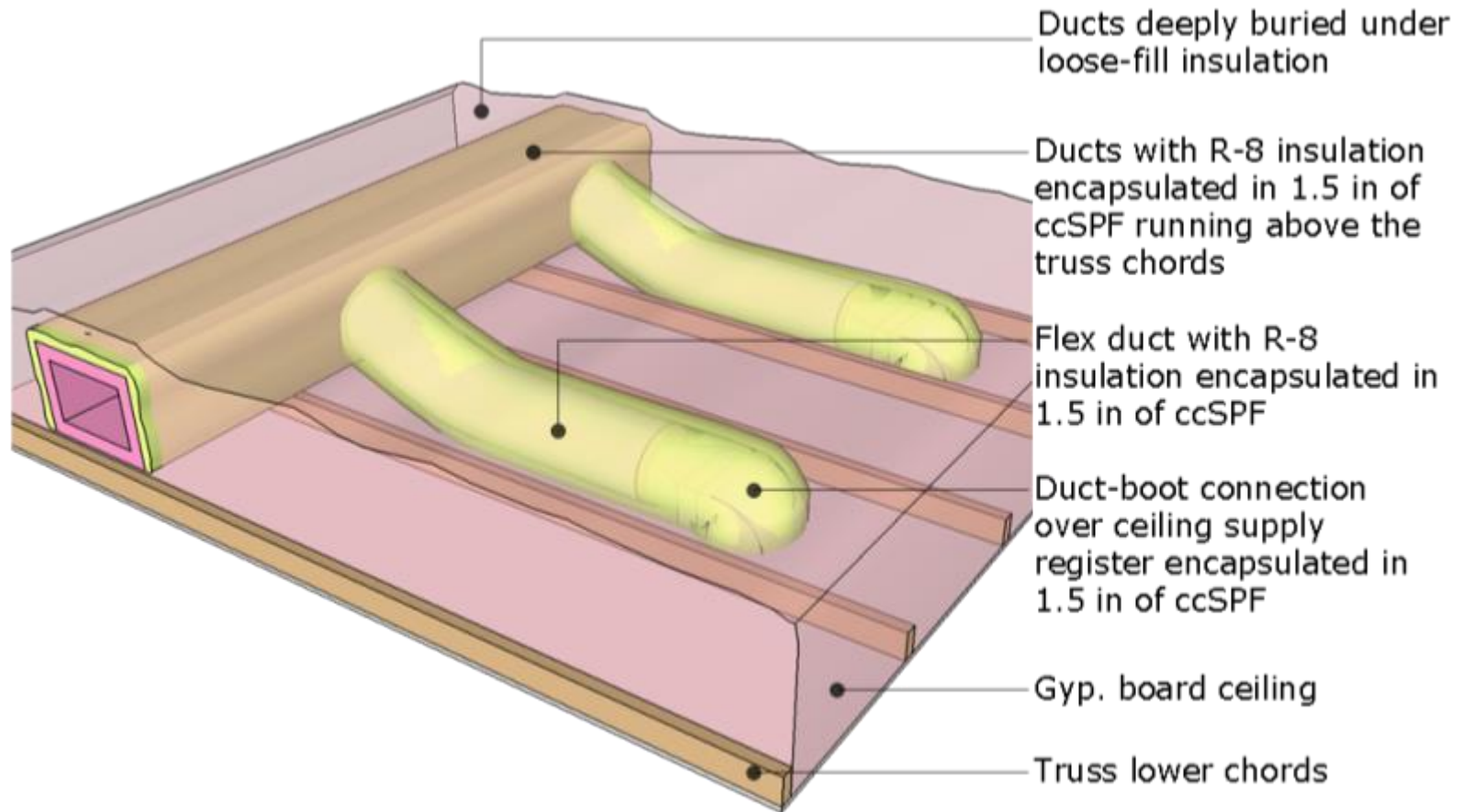



- Buried Ducts



- Encapsulated Ducts



- Buried and Encapsulated Ducts

Buried Duct Classification

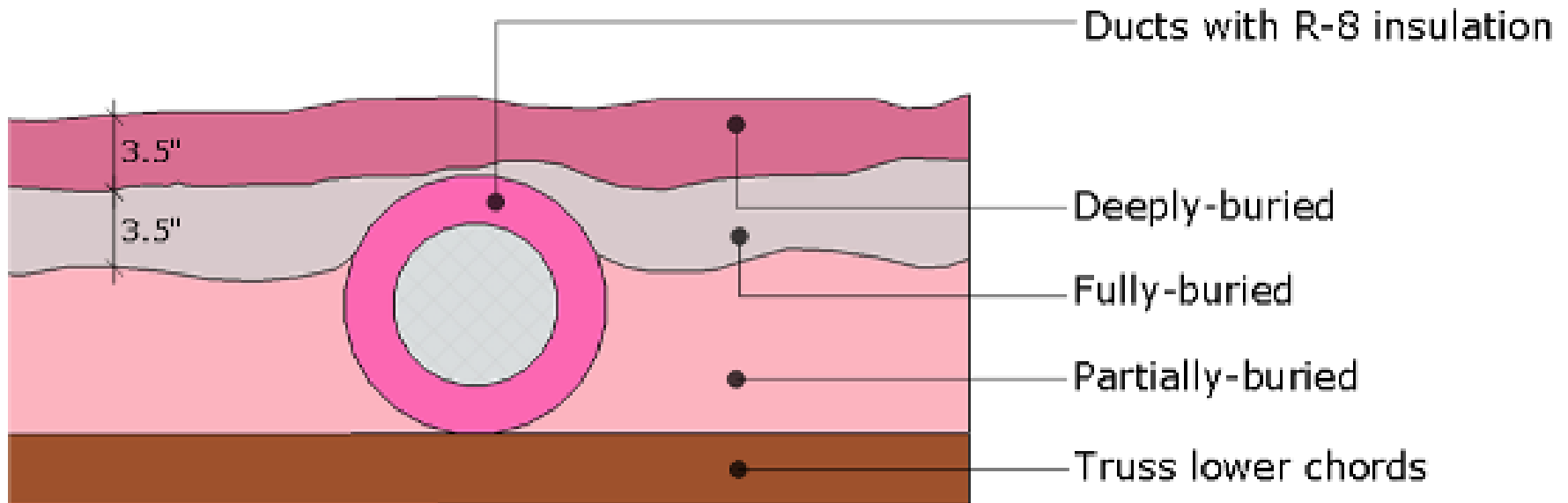

Buried Duct Schematic (Dry Climate Only)

Buried Duct Classification

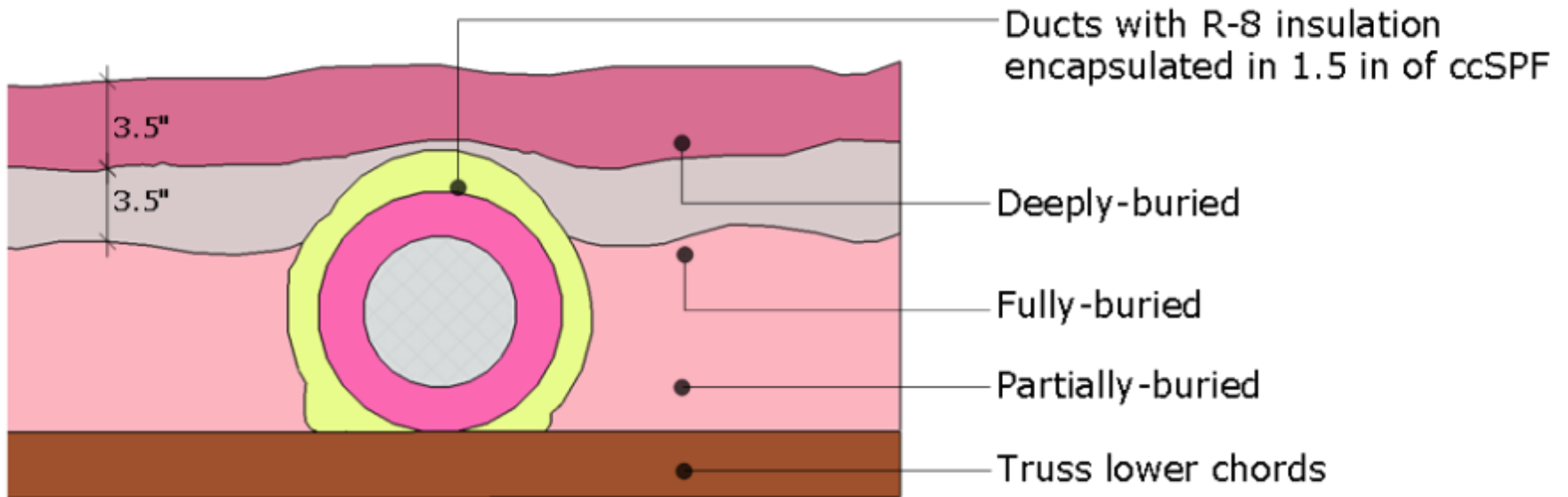

Buried & Encapsulated Duct Schematic (All Climates)

Effective R-values

Duct Configuration	R-4.2 Ducts	R-6 Ducts	R-8 Ducts
Traditional hung ducts	4.6	5.9	7.2
Hung ducts encapsulated in 1.5" of ccSPF	11.3	12.0	12.7
Partially-buried	8.1	10.2	12.3
Fully-buried	12.0	14.1	16.2
Deeply-buried	20.7	22.1	23.5
Encapsulated in 1.5" of ccSPF and partially-buried	18.4	19.7	21.0
Encapsulated in 1.5" of ccSPF and fully-buried	22.6	23.8	25.0
Encapsulated in 1.5" of ccSPF and deeply-buried	29.6	30.3	31.1

Condensation Potential

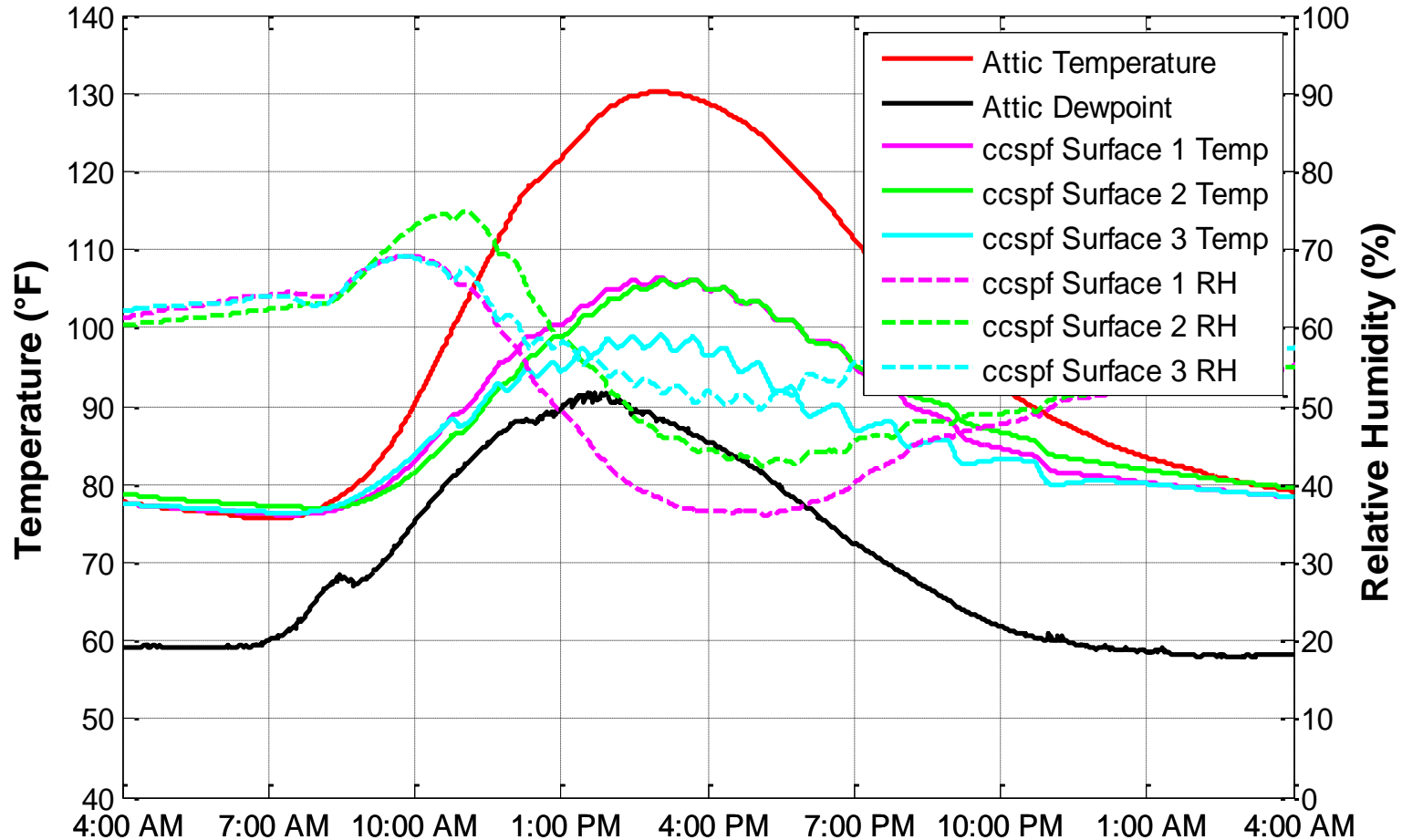

Install Low-Profile, Compact Duct Design



- Before ceiling drywall



- After ceiling drywall



- **Test total duct leakage** to assure performance levels are met (total leakage ≤ 3 cfm25 per 100 ft² of conditioned space)

Apply 1.5” minimum ccSPF



- ccSPF applied prior to ceiling gypsum board

Apply 1.5" minimum ccSPF



ccSPF applied after ceiling gypsum board



- Insulation must be ASTM classified as “mineral-fiber”, and must cover the ccSPF by a minimum of 1.5” (cellulose doesn’t qualify)
- Some foams are exempt from this requirement (more in a moment)

2009 IRC requires that spray foam insulation applied to the exterior of ductwork (Section M1601.3) in attics (Section R316.5.3) meet several requirements

- Flame spread index less than 25
- Smoke-developed index less than 450
- No attic storage or occupancy
- Spray foam protected by ignition barrier (1.5” mineral fiber)
 - Or meets R316.6 (no ignition barrier required)



- Code-related considerations:
 - IRC Sections R807.1, M1601.3, R316.5.3, R316.6
 - DOE Challenge Home
 - Title 24 of California Code of Regulations
- Technical References:
 - Multiple research reports since 2000
 - Upcoming BA Technical Report
 - Upcoming BA Measure Guideline

www.buildingamerica.gov

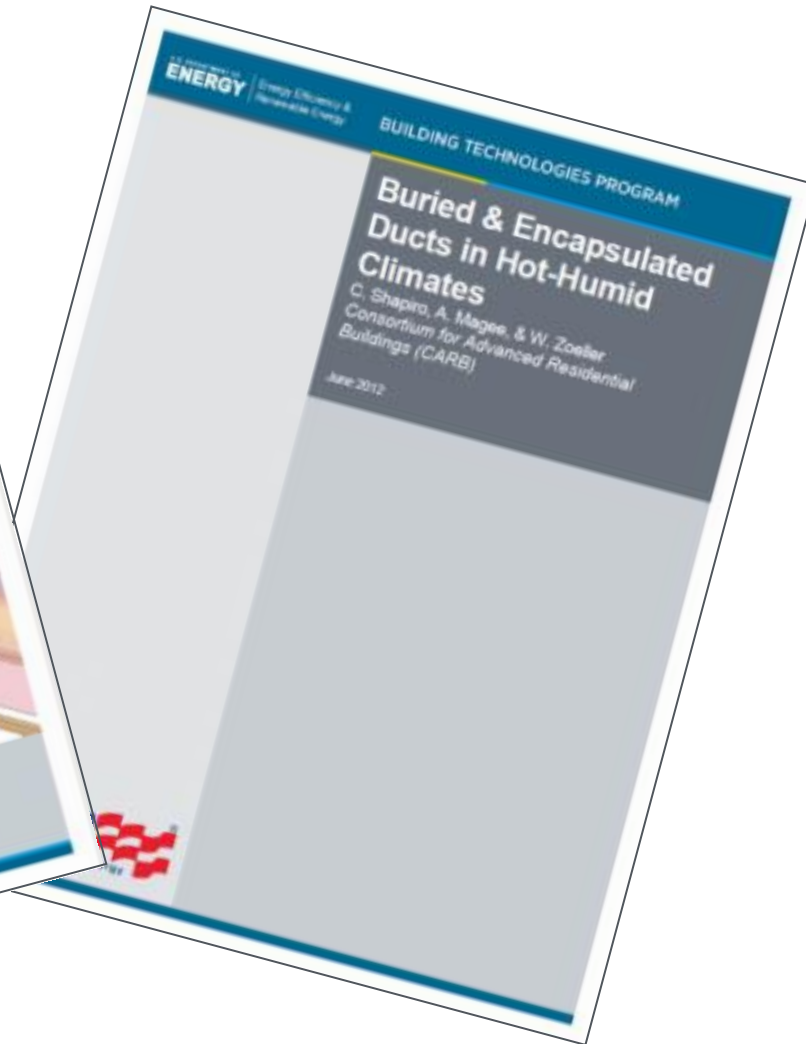

Zero Net-Energy Ready

Technical Specifications: Best Practices Super Air-Tight Construction

	ACH50 Requirements/Targets			
Climate Zones	DOE Challenge Home	ENERGY STAR V3*	2012 IECC	Passive House
1-2	3.0	6.0	5.0	0.6
3-4	2.5	5.0	3.0	0.6
5-7	2.0	4.0	3.0	0.6
8	1.5	3.0	3.0	0.6

* For ACH50 levels < these targets, UA tradeoffs are available

Chases/Shafts:

Access Panels:

Drywall at Top Plate:

Cracks:

Penetrations:

**Aggressively Seal
all the Usual Suspects**



Zero Net-Energy Ready

Technical Specifications: Best Practices 2012 IECC Insulation

Ceiling, wall, floor, and slab insulation shall meet or exceed 2012 IECC levels [Table R402.1.1].

The following [4] exceptions apply:

- a) Steel-frame ceilings, walls, & floors Table 402.2.6.
If 16" o.c. wood-framed wall w/R-13 specified,
then a 16" o.c. steel-framed wall can be

R-0 + 9.3;

R-13 + 4.2;

R-15 + 3.8;

R-19 + 3.1; or

R-21 + 2.8.

Ceiling, wall, floor, and slab insulation shall meet or exceed 2012 IECC levels [Table R402.1.1].

The following [4] exceptions apply:

- b) For ceilings with attic spaces, R-30 satisfies R-38 requirement, R-38 satisfies R-49 requirement wherever the full height of uncompressed insulation at the lower R-value extends over the wall top plate at the eaves. This exemption shall not apply if the alternative calculations in d) are used;

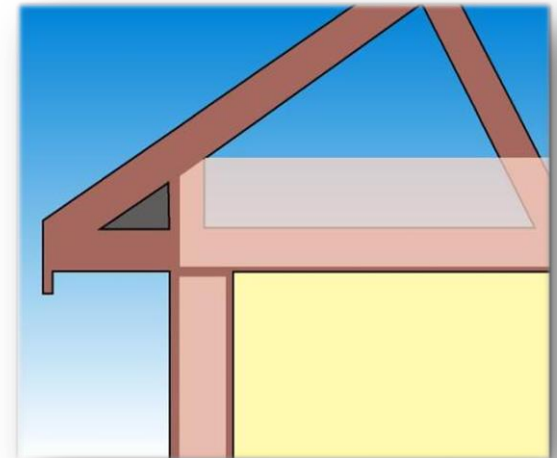

Ceiling, wall, floor, and slab insulation shall meet or exceed 2012 IECC levels [Table R402.1.1.]

The following [4] exceptions apply:

- c. For ceilings w/o attic spaces, R-30 okay if above R-30 required, but there is insufficient clearance.

Limited to 500 sq. ft. or 20% of total insulated ceiling area, whichever is less. This exemption shall not apply if the alternate calculations in d) are used;

Implication: Designs with extensive cathedral ceilings may need to incorporate SPF or rigid insulation; unvented attic designs may also be incorporated

Ceiling, wall, floor, and slab insulation shall meet or exceed 2012 IECC levels [Table R402.1.1}.

The following [4] exceptions apply:

- d) An alternate equivalent U-factor or total UA calculation:
- **U-factor** equal or less than Table 402.1.3.
 - Total building **thermal envelope UA** \leq to the total UA from U-factors in Table 402.1.3.
 - ~~Fenestration products (i.e., windows, skylights, doors) not included in this calculation.~~
 - Attic eave, slab edge, and attic platform insulation reqts. (4.1 through 4.3 of the ES for Homes V3 TES) shall be met.
 - The UA calculation method consistent with ASHRAE HOF and include thermal bridging effects: ASHRAE zone method or equivalent, and not a series-parallel path calculation method.

Software Note: Evaluating & Diagnosing UA Compliance

- REM/Rate V14.2 models this UA Calculation approach automatically
- Non-compliance messages will show up if envelope doesn't meet 2012 IECC UA
- Use “2012 IECC Building UA Compliance” for diagnosing issues
 - Don't include fenestration

Report - C:\Users\Public\Architectural Energy Corporation\REM Rate 12\Reports\IECCUA12.ll

Viewing: IECC 2012 UA Compliance (1) << Report Report >> Print All Reports...

1 of 1 100% 1:1

2012 IECC Building UA Compliance

Property: Howard Homeowner, 555 Main Street, Rockville, MD 20853
Organization: Newport
HERS Rater ID:
Builder:

Weather: Baltimore, MD
DOE Challenge Home - Target CZ4
DCH Target Home Design - CZ4.2

Elements	Insulation Levels	
	2012 IECC	As Designed
Shell UA Check		
Ceilings:	34.9	34.9
Above-Grade Walls:	132.2	128.4
Windows and Doors:	115.2	91.9
Basement Walls:	69.2	67.7
Overall UA (Design must be equal or lower):	351.5	322.9
Window U-Factor Check (Section 402.5)		
Window U-Factor (Design must be equal or lower):	0.480	0.300

This home MEETS the overall thermal performance requirements and verifications of the International Energy Conservation Code based on a climate zone of 4A. (Section 402, International Energy Conservation Code, 2012 edition.) In fact, this home

- Plan Review Feedback
- Common Issues
 - Design HERS > Target Home HERS
 - Failure to Check Mandatory Boxes
 - 2012 IECC UA Not Low Enough
 - Unvented attics can be tricky
 - Duct not in conditioned space

DOE Challenge Home Verification

Projected Rating: Based on Plans - Field Confirmation Required.

The building DOES NOT meet DOE CHALLENGE for the following reasons:

The Design Home HERS Index is larger than the DOE Challenge HERS Index Target.

- HERS Index w/o PV is 56
- HERS Index with PV is 56
- DOE Challenge HERS Index Target w/o SAF is 53
- DOE Challenge HERS Index Target w/SAF is 53

The HERS Index w/o PV must be lower than the DOE Challenge HERS Index Target w/o SAF AND the HERS Index with PV must be lower than the DOE Challenge HERS Index Target with SAF.

Energy Performance	
House Type	DOE Challenge Home Builder Partner ID#
Single-family detached	12345
Year built	Square footage of Conditioned Space including Basement
2013	3968.0
Number of Bedrooms	Square footage of Conditioned Space without Basement
4	2368.0
Site address (if not available, list the site Lot #)	Registered Builder
555 Main Street	
Rockville	Certified Rater
MD, 20853	
HERS Index without On-site Generation	Date of Rating
56	
HERS Index with On-site Generation	Rating Software
56	REM/Rate - v14.1
HERS Index of the Target Home using size adjustment factor	Estimated annual energy costs(\$)
53	1428
Estimated annual energy use	Estimated annual energy savings
Electric: 14986 kWh \ Natural Gas: 220 Therms	Electric: 10648 kWh \ Natural gas: -9 Therms
Energy cost rates	Estimated annual emissions reductions
Electric: 0.08 \$/kWh \ Natural Gas: 0.50 \$/Therms	CO2: 7.0 tons / SO2: 116.5 lbs / NOx: 26.1 lbs

DOE Challenge Home Certification	
As the certified Rater for this house, I certify this house meets/complies with all mandatory requirements of the DOE Challenge home guidelines, including the following:	
	Compliance with all ENERGY STAR Qualified Homes Version 3 requirements and checklists
X	Compliance with Mandatory Fenestration Requirements

IECC Climate Zones

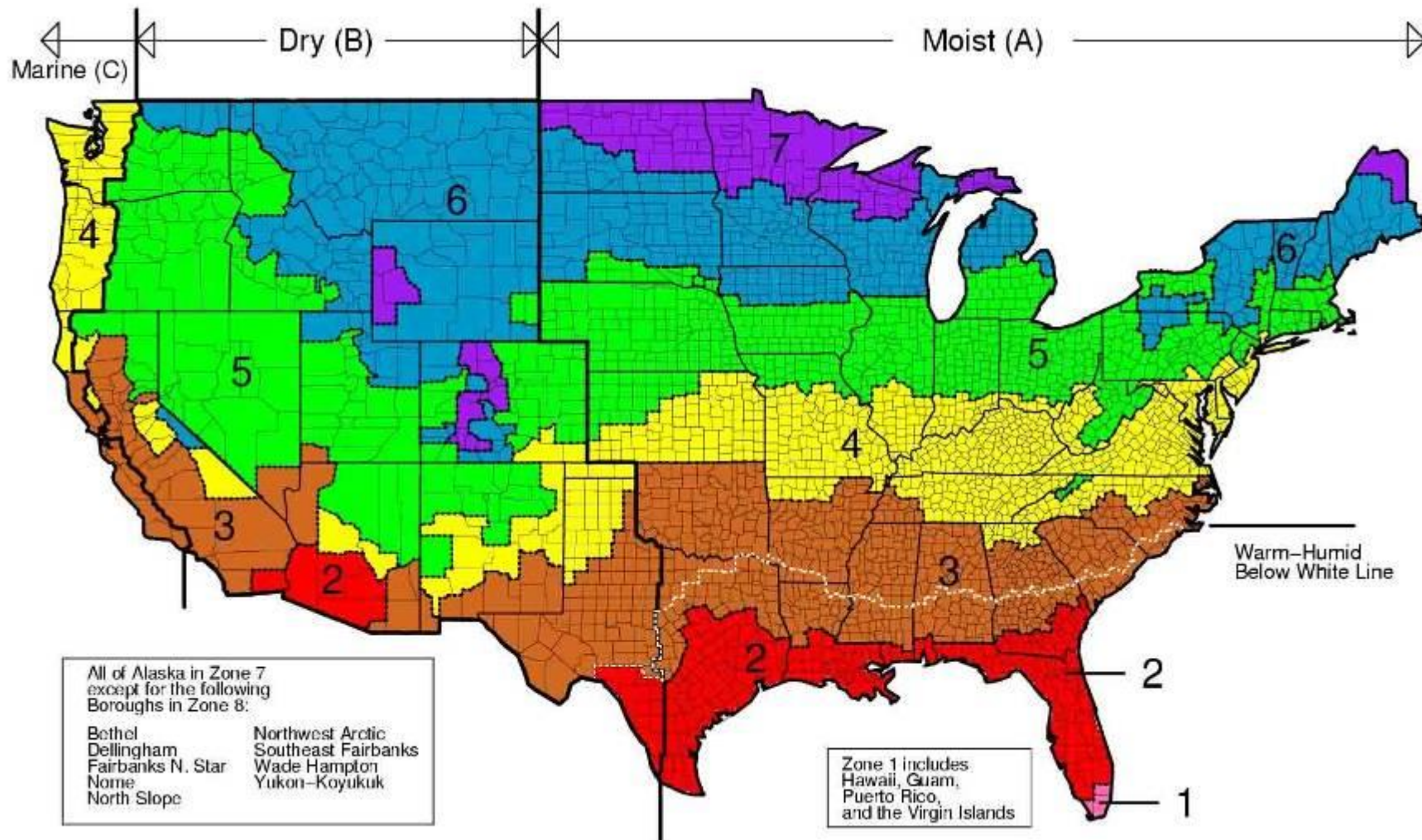

Prescriptive Requirements

Climate Zone	Fenestration	Skylight U-Factor	Glazed Fenestration SHGC	Ceiling R-Value	Wood Frame Wall R-Value
1	NR	0.75	0.25	30	13
2	0.40	0.65	0.25	38	13
3	0.35	0.55	0.25	38	20 or 13+5 ^h
4 except Marine	0.35	0.55	0.40	49	20 or 13+5 ^h
5 & Marine 4	0.32	0.55	NR	49	20 or 13+5 ^h
6	0.32	0.55	NR	49	20+5 or 13+10 ^h
7 & 8	0.32	0.55	NR	49	20+5 or 13+10 ^h

Prescriptive Requirements, continued

Climate Zone	Mass Wall R-Value ⁱ	Floor R-Value	Basement ^c Wall R-Value	Slab ^d R-Value, Depth	Crawl Space ^c Wall R-Value
1	3/4	13	0	0	0
2	4/6	13	0	0	0
3	8/13	19	5/13 ^f	0	5/13
4 except Marine	8/13	19	10 /13	10, 2 ft	10/13
5 & Marine 4	13/17	30 ^g	15/19	10, 2 ft	15/19
6	15/20	30 ^g	15/19	10, 4 ft	15/19
7 & 8	19/21	38 ^g	15/19	10, 4 ft	15/19

ASSEMBLY	R/U
Fenestration U-Factor ^b	NR
Skylight U-Factor	0.75
Glazed Fenestration SHGC ^{b, e}	0.25
Ceiling R-Value	30
Wood Wall R-Value	13
Mass Wall R-Value ⁱ	3 / 4
Floor R-Value	13
Basement ^c Wall R-Value	0
Slab ^d R-Value, Depth	0
Crawlspace ^c Wall R-Value	0

- b. Skylights exempt from SHGC requirements in CZ 1-3 if SHGC \leq 3.0
- d. R-5 shall be added for heated slabs to footing or 2'
- i. R-4 required if more than half of insulation is on interior

ASSEMBLY	R/U
Fenestration U-Factor ^b	0.40
Skylight U-Factor	0.65
Glazed Fenestration SHGC ^{b, e}	0.25
Ceiling R-Value	38
Wood Wall R-Value	13
Mass Wall R-Value ⁱ	4 / 6
Floor R-Value	13
Basement ^c Wall R-Value	0
Slab ^d R-Value, Depth	0
Crawlspace ^c Wall R-Value	0

- b. Skylights exempt from SHGC requirements in CZ 1-3 if SHGC \leq 3.0
- d. R-5 shall be added for heated slabs to footing or 2'
- i. R-4 required if more than half of insulation is on interior

ASSEMBLY	R/U
Fenestration U-Factor ^b	0.35
Skylight U-Factor	0.55
Glazed Fenestration SHGC ^{b, e}	0.25
Ceiling R-Value	38
Wood Wall R-Value	20 or 13+5 ^h
Mass Wall R-Value ⁱ	8 / 13
Floor R-Value	19
Basement ^c Wall R-Value	5 / 13 ^f
Slab ^d R-Value, Depth	0
Crawlspace ^c Wall R-Value	5 / 13

- b. Skylights exempt from SHGC requirements in CZ 1-3 if SHGC \leq 3.0
- c. R-5 continuous or R-13 cavity on interior
- d. R-5 shall be added for heated slabs to footing or 2'
- f. Basement wall insulation not required in warm humid locations (see map)
- h. Cavity insulation or cavity + continuous
- i. R-13 reqd. if more than half of insulation is on interior

ASSEMBLY	R/U
Fenestration U-Factor ^b	0.35
Skylight U-Factor	0.55
Glazed Fenestration SHGC ^{b, e}	0.40
Ceiling R-Value	49
Wood Wall R-Value	20 or 13+5 ^h
Mass Wall R-Value ⁱ	8 / 13
Floor R-Value	19
Basement ^c Wall R-Value	10 / 13
Slab ^d R-Value, Depth	10, 2 ft
Crawlspace ^c Wall R-Value	10 / 13

- b. SHGC applies to all fenestration
- c. R-10 continuous or R-13 cavity on interior
- d. R-5 shall be added for heated slabs
- h. Cavity insulation or cavity + continuous
- i. R-13 required if more than half of insulation is on interior

ASSEMBLY	R/U
Fenestration U-Factor ^b	0.35
Skylight U-Factor	0.55
Glazed Fenestration SHGC ^{b, e}	0.40
Ceiling R-Value	49
Wood Wall R-Value	20 or 13+5 ^h
Mass Wall R-Value ⁱ	13 / 17
Floor R-Value	30 ^g
Basement ^c Wall R-Value	15/19.
Slab ^d R-Value, Depth	10, 2 ft.
Crawlspace ^c Wall R-Value	15/19

- c. R-15 continuous or R-19 cavity on interior
- d. R-5 shall be added for heated slabs
- e. No SHGC reqts. in Marine Zone
- g. Or insulation sufficient to fill framing cavity
- h. Cavity insulation or cavity + continuous
- i. R-17 required if more than half of insulation is on interior

ASSEMBLY	R/U
Fenestration U-Factor ^b	0.32
Skylight U-Factor	0.55
Glazed Fenestration SHGC ^{b, e}	NR
Ceiling R-Value	49
Wood Wall R-Value	20 + 5 or 13+10 ^h
Mass Wall R-Value ⁱ	15/20
Floor R-Value	30 ^g
Basement ^c Wall R-Value	15/19
Slab ^d R-Value, Depth	10, 4 ft.
Crawlspace ^c Wall R-Value	15/19

- c. R-15 continuous or R-19 cavity on interior
- d. R-5 shall be added for heated slabs
- g. Or insulation sufficient to fill framing cavity
- h. Cavity insulation or cavity + continuous
- i. R-20 required if more than half of insulation is on interior

ASSEMBLY	R/U
Fenestration U-Factor ^b	0.32
Skylight U-Factor	0.55
Glazed Fenestration SHGC ^{b, e}	NR
Ceiling R-Value	49
Wood Wall R-Value	20 + 5 or 13+10 ^h
Mass Wall R-Value ⁱ	19/21
Floor R-Value	38 ^g
Basement ^c Wall R-Value	15/19
Slab ^d R-Value, Depth	10, 4 ft.
Crawlspace ^c Wall R-Value	15/19

- c. R-15 continuous or R-19 cavity on interior
- d. R-5 shall be added for heated slabs
- g. Or insulation sufficient to fill framing cavity
- h. Cavity insulation or cavity + continuous
- i. R-21 required if more than half of insulation is on interior

Equivalent U-Factors ^a

Climate Zone	Fenestration	Skylight U-Factor	Ceiling U-Factor	Frame Wall U-Factor
1	0.50	0.75	0.035	0.082
2	0.40	0.65	0.030	0.082
3	0.35	0.55	0.030	0.057
4 except Marine	0.35	0.55	0.026	0.057
5 & Marine 4	0.32	0.55	0.026	0.057
6	0.32	0.55	0.026	0.048
7 & 8	0.32	0.55	0.026	0.048

^A Non-fenestration U-factors shall be obtained from measurement, calculation, or an approved source.

Equivalent U-Factors (cont.)

Climate Zone	Mass Wall U-Factor ^b	Floor U-Factor	Basement Wall U-Factor	Crawl Space Wall U-Factor
1	0.197	0.064	0.360	0.477
2	0.165	0.064	0.360	0.477
3	0.098	0.047	0.091 ^c	0.136
4 except Marine	0.098	0.047	0.059	0.065
5 & Marine 4	0.082	0.033	0.050	0.055
6	0.060	0.033	0.050	0.055
7 & 8	0.057	0.028	0.050	0.055

^b When more than half of insulation is on interior, following maximum U-factors apply: CZ1-0.17, CZ2 – 0.14, CZ3 – 0.12, CZ4 (except Marine) – 0.087, CZ5 CZ4 Marine – 0.065, CZ6 -8 – 0.057.

Minimum R-value of impermeable insulation

Climate Zone	Minimum Impermeable Insulation R-Value
2B and 3B Tile Roof	None Required
1, 2A, 2B, 3A, 3B, 3C	R-5
4C	R-10
4A, 4B	R-15
5	R-20
6	R-25
7	R-30
8	R-35

Zero Net-Energy Ready

Technical Specifications: Best Practices Super Windows

- Challenge Home Minimum:
Slightly Better Than ENERGY STAR

	Hot Climates IECC CZ 1-2	Mixed Climates IECC CZ 3-4 except Marine	Cold Climates IECC CZ 5-8 and 4 Marine
SHGC	0.25	0.27	Any
U-Value	0.4	0.3	0.27

- Challenge Home Encouraged:
R-5 Window (U-Value ~.2)

Zero Net-Energy Ready

Technical Specifications: Best Practices Efficient Low-Load HVAC

- Challenge Home Target Home Specifications:

	Hot Climates IECC CZ 1-2	Mixed Climates IECC CZ 3-4 except Marine	Cold Climates IECC CZ 5-8 and 4 Marine
AFUE	80%	90%	94%
SEER	18	15	13
HSPF	8.2	9	10
Geo HP	ENERGY STAR EER and COP Criteria		
ASHRAE 62.2 Whole-House Ventilation	1.4 cfm/W: no heat exch.	1.4 cfm/W: no heat exch.	1.2 cfm/W: w/heat exch. 60% SRE

- Challenge Home Technology Options
 - Variable-Speed or multi-stage
 - Ductless Mini-Split Heat Pump Systems
 - GSHPs
 - Combo-Systems [e.g., heat, water heating, vent.]

- WHMV Fan Efficiency

- For an example home of 4 BR and 2500 SF:

- $Q_{fan} = 0.01 * A_{floor} + 7.5(N_{br} + 1)$
- $= 0.01 * (2500) + 7.5 * (5) = 63 \text{ cfm}$

CZ 1-2	CZ 3, 4 (except Marine)	CZ 4 Marine, 5-8
1.4 cfm/W	1.4 cfm/W	1.2 cfm/W
No heat exchange	No heat exchange	HX with 60% SRE

- $63 \text{ cfm} / (1.4 \text{ cfm/W}) = 45 \text{ Watts}$
- More efficient WHMV systems can use lower Watts, gain HERS

Zero Net-Energy Ready

Technical Specifications: Efficient Components

- ENERGY STAR Certified Appliances
 - Refrigerators
 - Dishwashers
 - Clothes Washers
- ENERGY STAR Certified Lighting
 - Fixtures (CFL or LED)
 - Bulbs (CFL or LED)
- ENERGY STAR Certified Fans
 - Ceiling
 - Bathroom Ventilation

- ENERGY STAR Gas Water Heating
 - Storage with EF \geq 0.67
 - “Extra Credit”:
 - Whole-Home Tankless with EF \geq 0.82
 - Condensing with EF \geq 0.8
- ENERGY STAR Electric Water Heating
 - Heat Pump Water Heater with EF \geq 2.0
- ENERGY STAR Solar Water Heating
 - Solar with SF \geq 0.5
- Oil Water Heating
 - Any oil-fired water heater with EF \geq 0.6

- Heat Pump Clothes Dryer
- Induction Cooktop

Typical Clothes Dryer Inefficiency

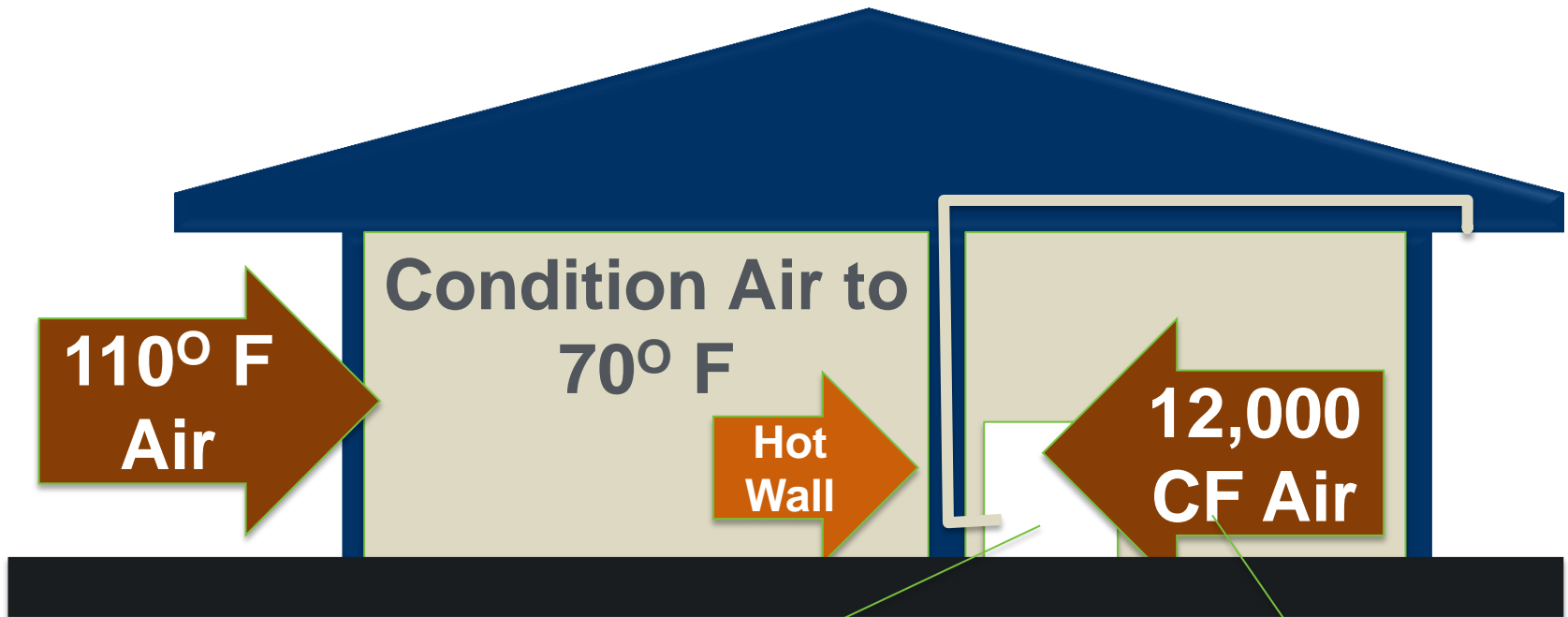

Heat 70° F air to 125° F, circulate to remove moisture, and then exhaust

All the air in a 1,500 sf home is exhausted out over a 60 minute cycle

Typical Clothes Dryer Hot Wall

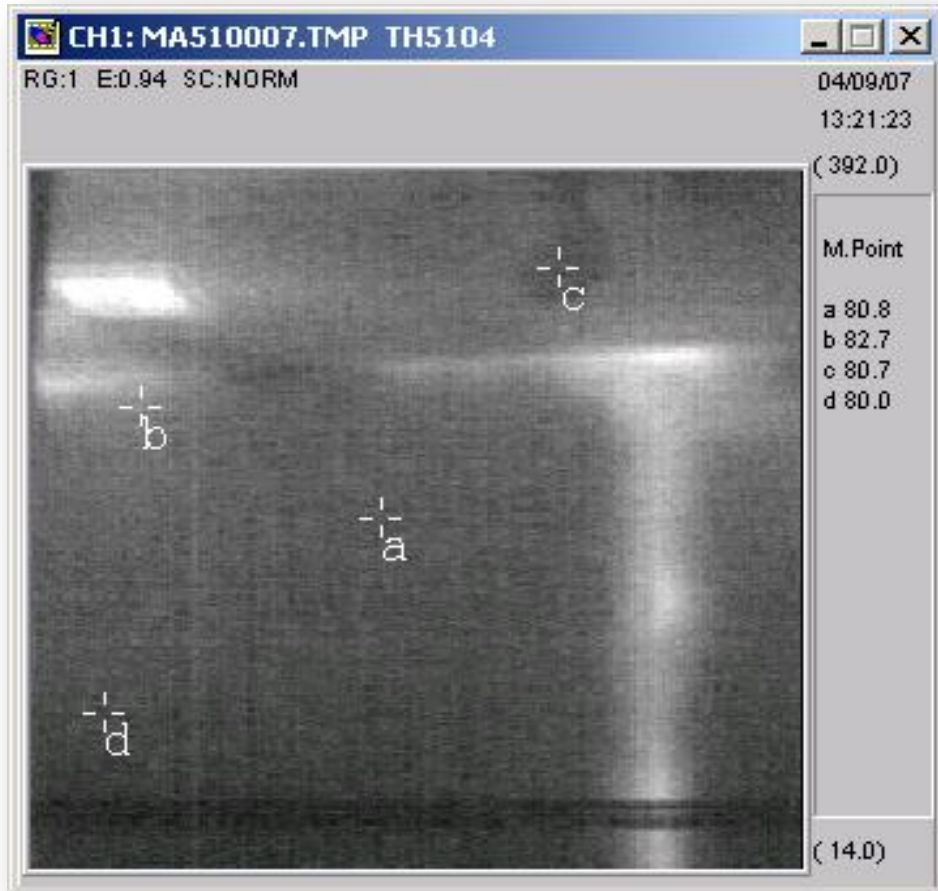

Dryer Not



After 40 Minutes

Wärmepumpentrockner - Aufbau

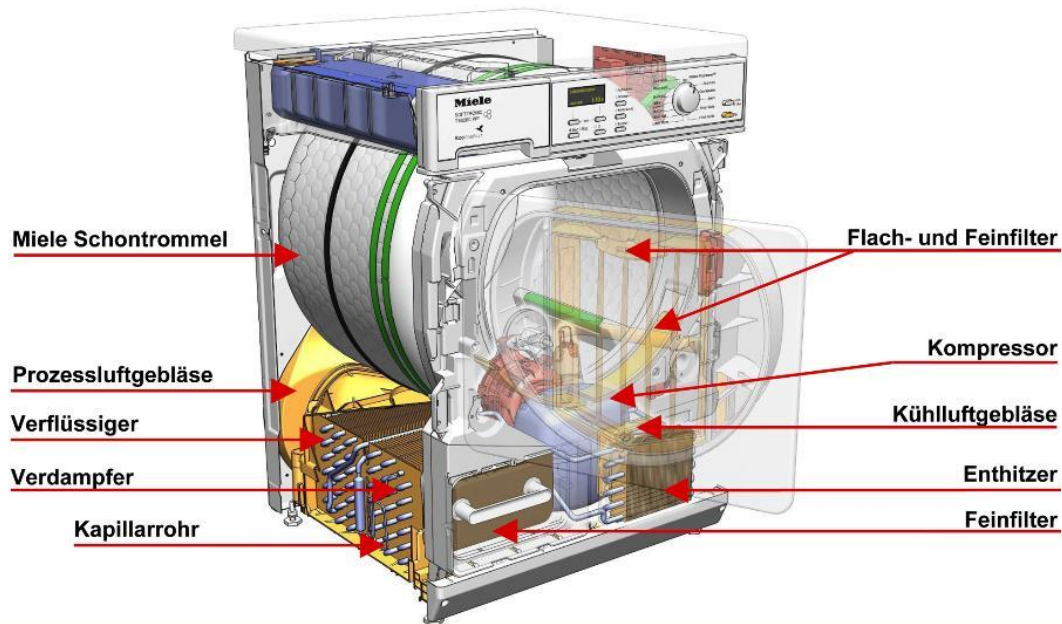

4.5 vs. 12,000 CF Air Plus No Exhaust Vent

Advanced Induction Cooktop

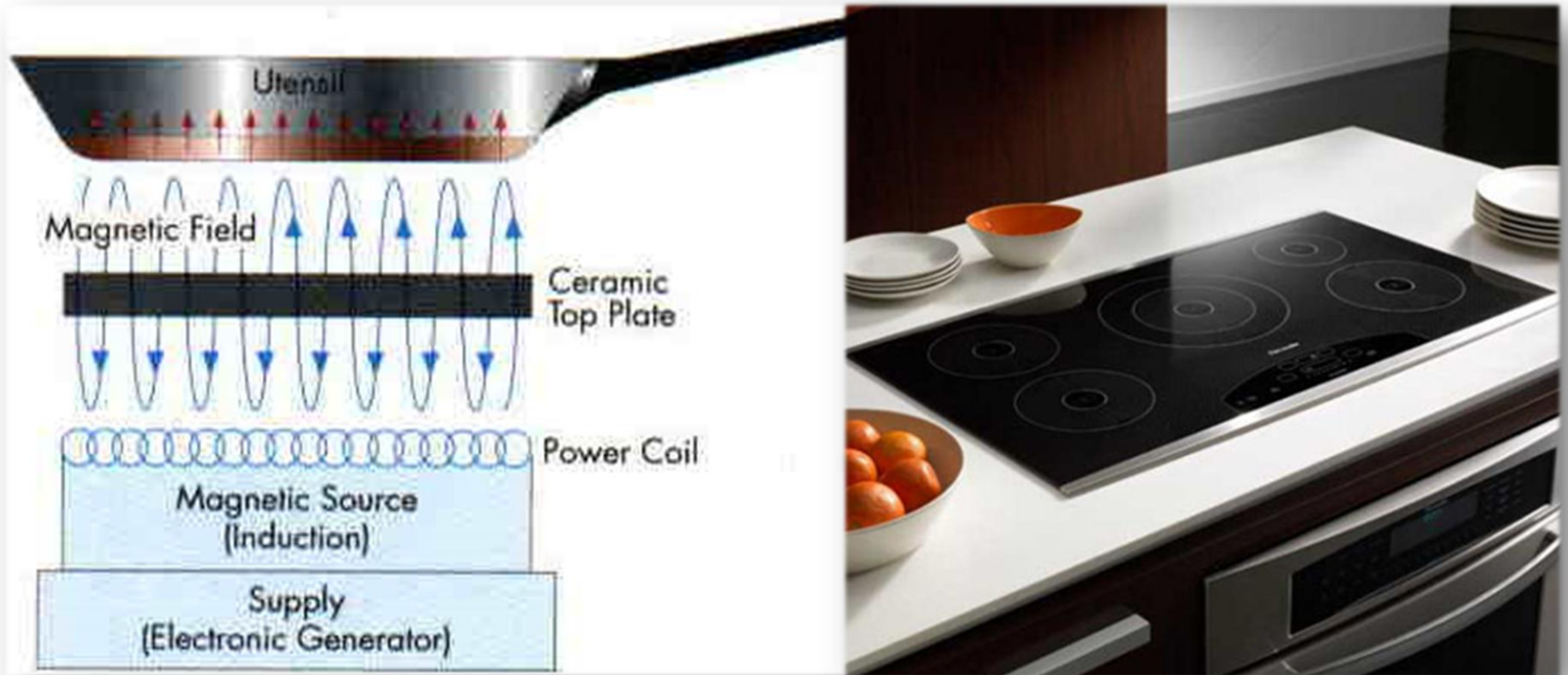

Zero Net-Energy Ready

Technical Specifications: Indoor Air Quality

Maryland

Type	Name	Phone	Notes
Builder	AllanHomes Unlimited EXIT Disclaimer	(410) 381-1414	
Builder	Bethesda Bungalows EXIT Disclaimer	(301) 656-2776	
Builder	Chadsworth Homes, Inc. EXIT Disclaimer	(301) 315-8038	
Builder	Congressional Design Build, Inc. EXIT Disclaimer	(240) 744-0009	
Builder	Finish Werks, LLC EXIT Disclaimer	(410) 514-6222	
Builder	Graham Built, Inc. EXIT Disclaimer	(781) 389-1685	
Builder	Choptank Habitat for Humanity EXIT Disclaimer Easton, MD	(410) 820-6186	 EXIT Disclaimer
Builder	Hamel Green Construction, LLC EXIT Disclaimer	(443) 956-4336	
Builder	Kettler Forlines Homes EXIT Disclaimer	(301) 674-4036	Kettler Forlines Homes builds Indoor airPLUS Qualified Community. Read more in our Partner Updates .
Builder	Meridian Homes, Inc. EXIT Disclaimer	(301) 652-4440	
Builder	Mid-Atlantic Builders, Inc.	(301) 231-0009 x219	
Builder	Mundi Homes, LLC EXIT Disclaimer	(240) 752-4718	
Builder	Nexus EnergyHomes EXIT Disclaimer	(410) 263-0012	
Builder	Paramount Construction EXIT Disclaimer	(301) 948-7238	
Builder	Parkwood Homes EXIT Disclaimer	(703) 300-3505	
Builder	... EXIT Disclaimer	(410) 500-5000	

- 2000 SF Home
 - 8.5' Ceilings
 - 3 ACH50 (2012 IECC requirement in CZ 3 – 8)
 - 200 cfm exhaust draw (e.g. dryer, range hood)
 - **- 5 Pa depressurization**
-
- Dust Mites – causative factor for asthma development
 - Radon Control – often overlooked (even in Radon Zone 1)
 - 20%+ households with significant respiratory issue

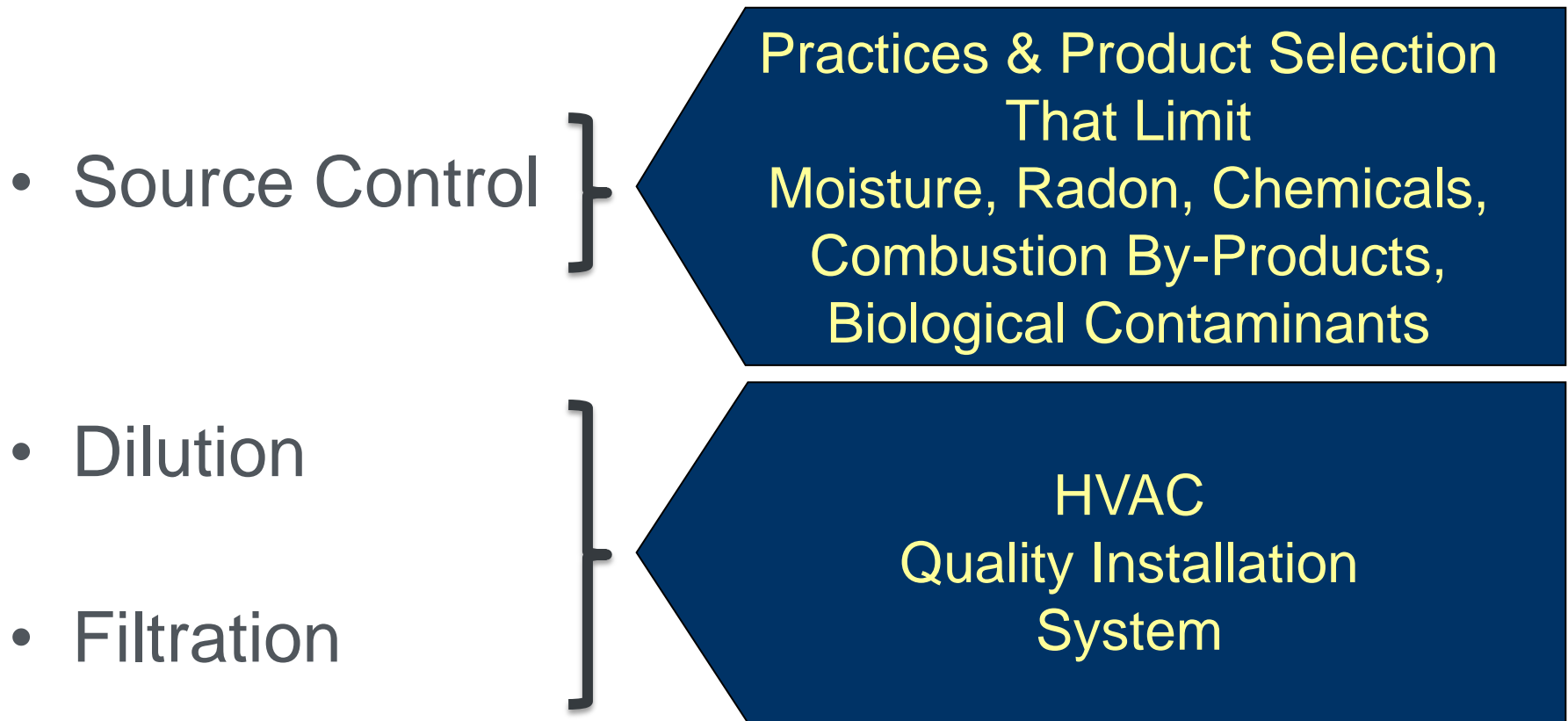

Source Control: Moisture Moisture Control System

- Air Sealing
- Air Barriers
- Water-Managed Roofs
- Water-Managed Walls/Opening
- Water Manage Foundation/Site
- Water Managed Materials
- Dehumidification in Warm-Humid Climates

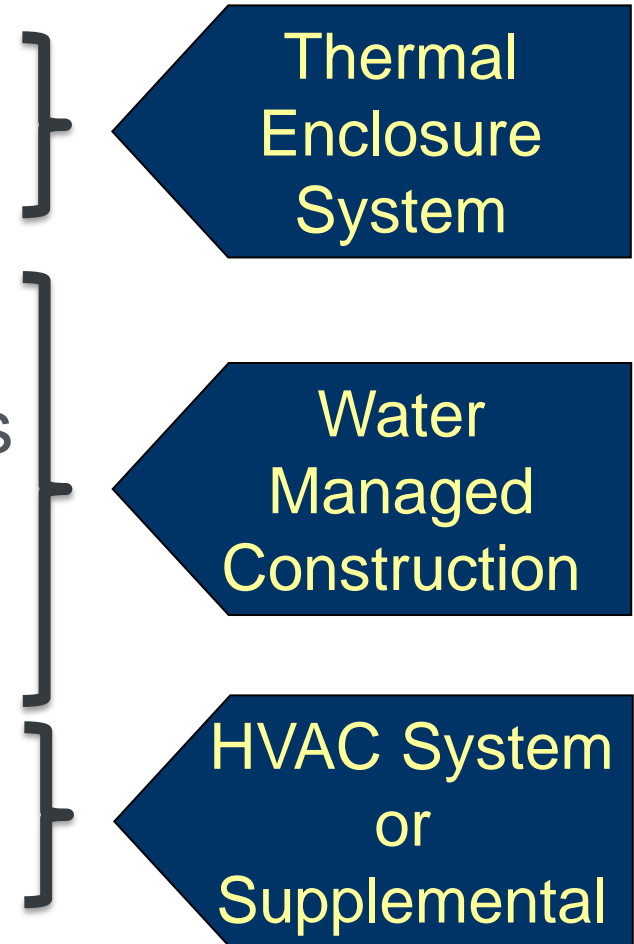

Source Control: Moisture Dehumidification in Warm-Humid CZs

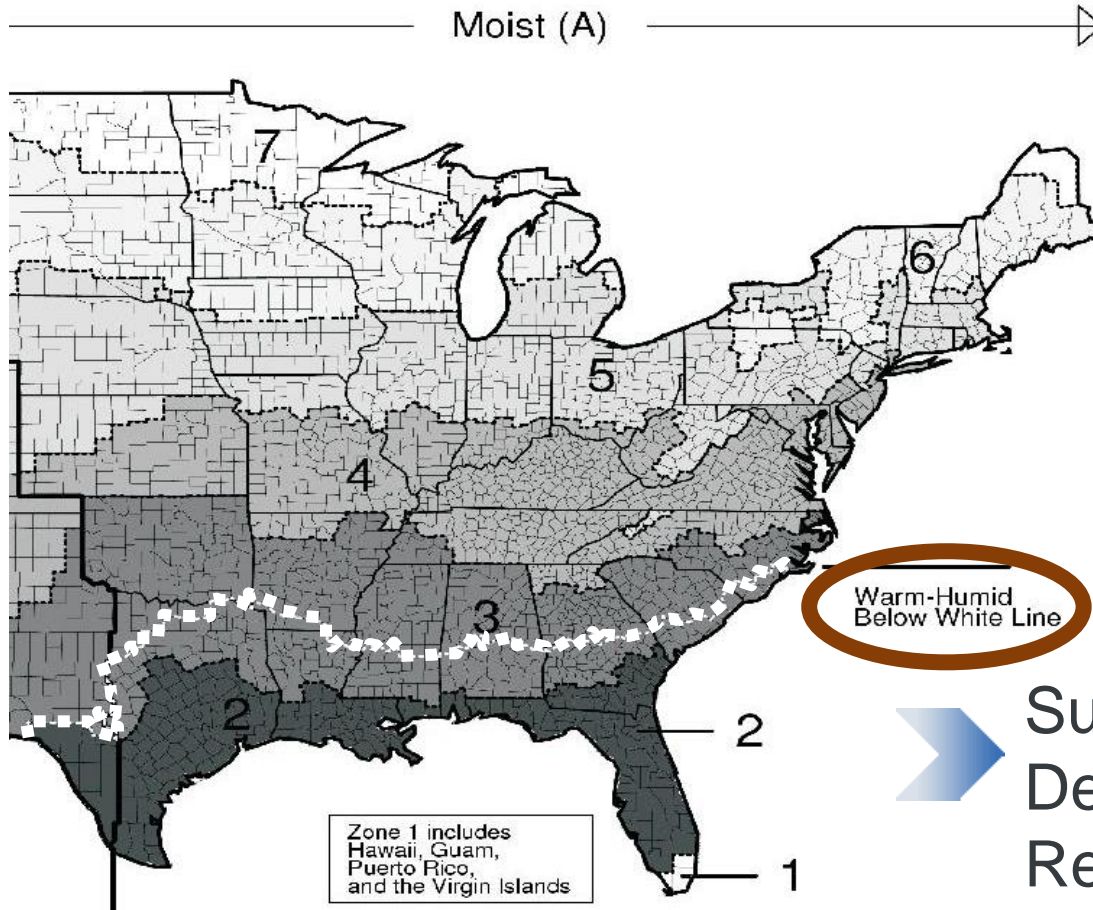

Dust mites in the billions
at 60% RH or high

➔ Supplemental
Dehumidification
Required for $\leq 60\%$ RH in
Warm-Humid Climates

Source Control: Radon Radon Zones in U.S.

EPA Map of Radon Zones

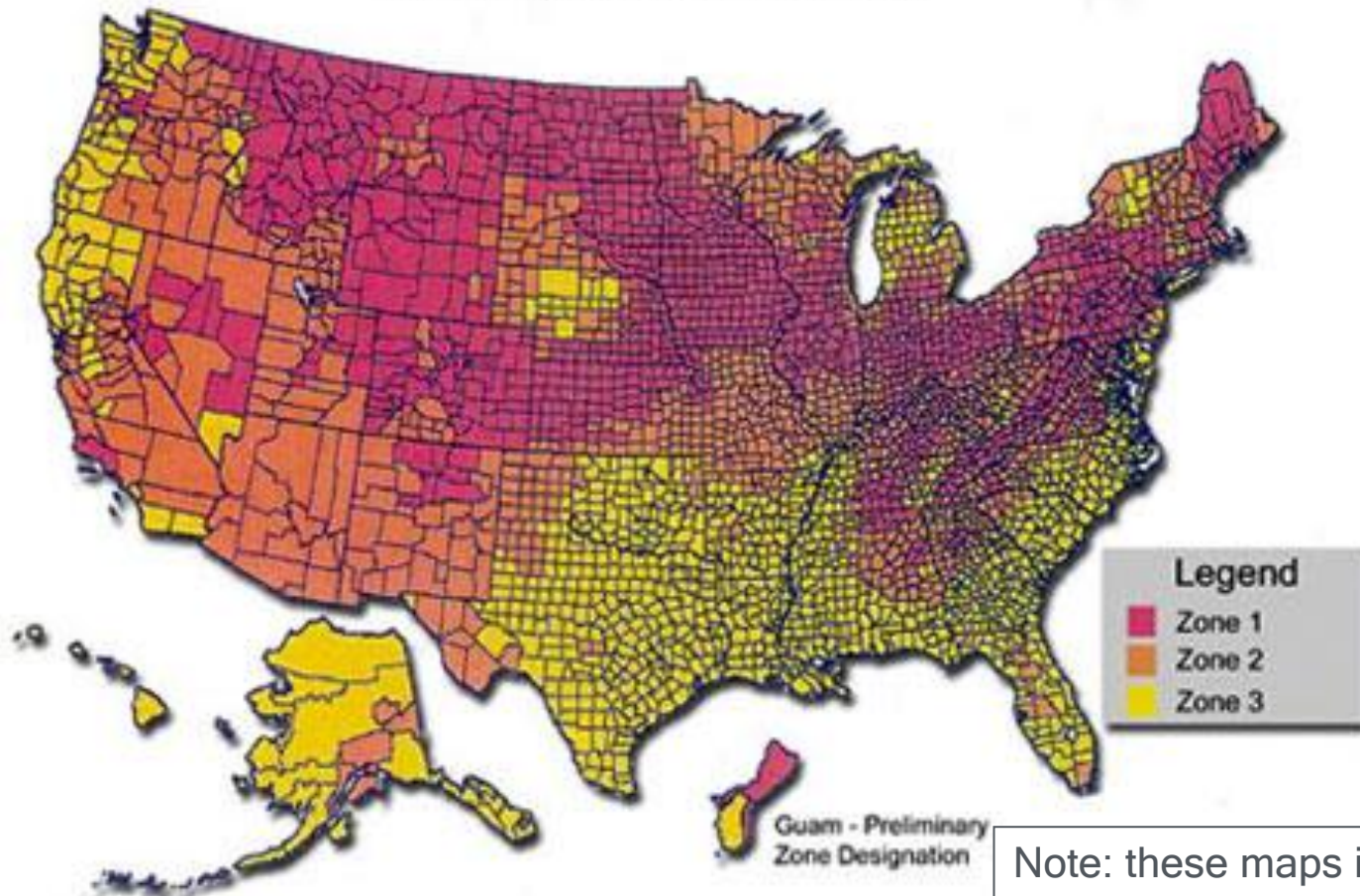

**Surgeon General's Warning:
Radon Causes Lung Cancer**

Note: these maps indicate average risk by county. However, High levels of Radon can be found in any home.

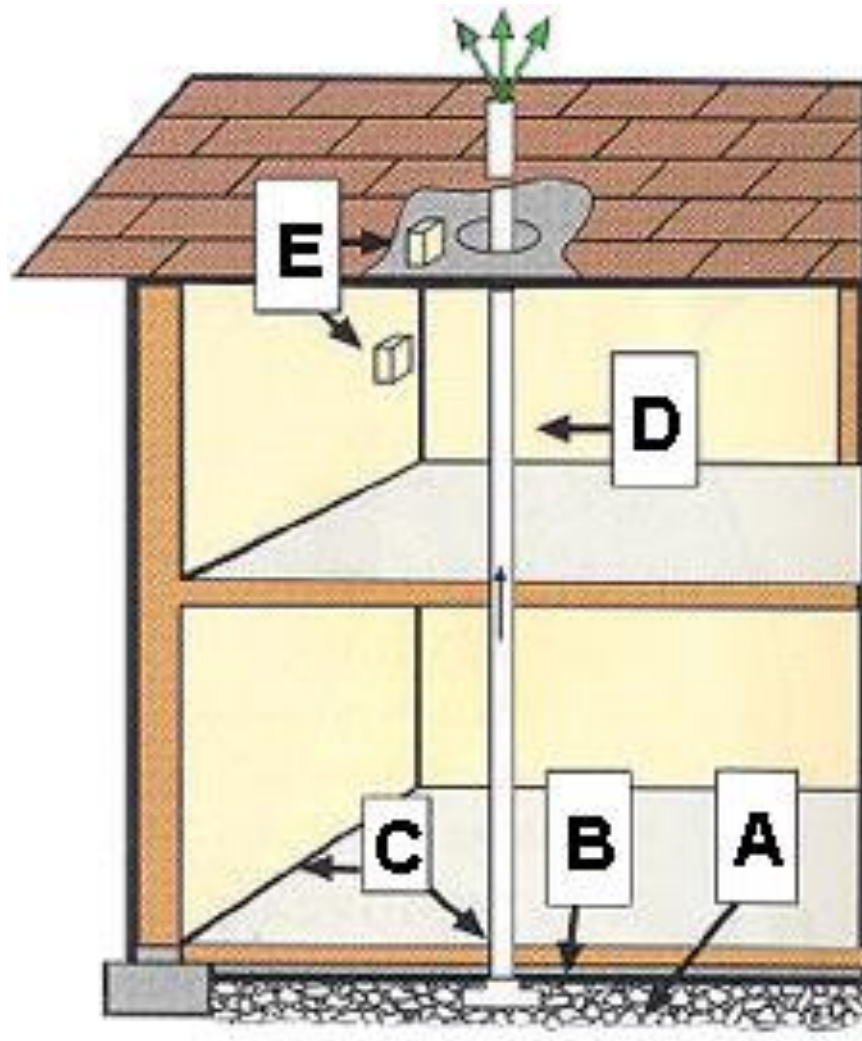

Required for Moisture Control:

- A. Gas Permeable Layer
(min. 4" clean gravel)
- B. Plastic Sheeting
(under slab)
- C. Sealing and Caulking
(all openings in concrete floor)
- D. Vent Pipe
(3 or 4 inch PVC pipe)
- E. Junction Box
(if fan needed later)

Source Control: Radon Radon Resistant Crawl Space

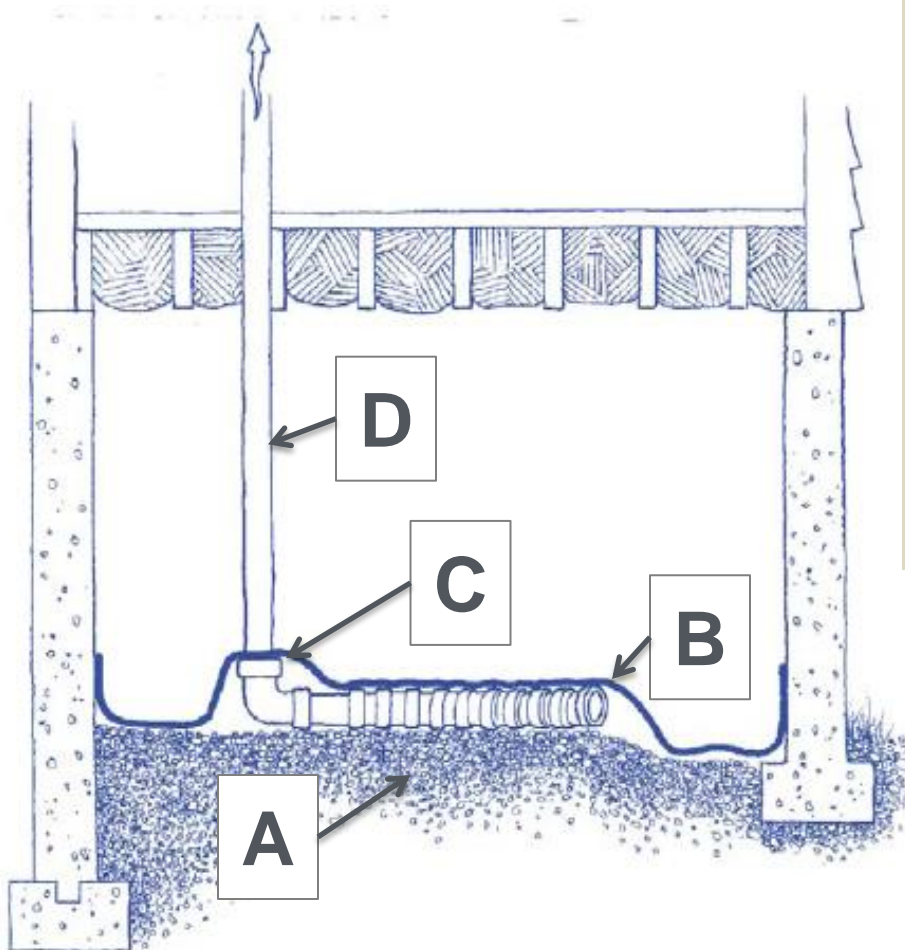

Required for Moisture Control:

- A. Gas Permeable Layer
(min. 4" clean gravel)
- B. Plastic Sheeting
(over crawl space)
- C. Sealing and Caulking
(all openings, overlapped seams)
- D. Vent Pipe
(3 or 4 inch PVC pipe)
- E. Junction Box
(if fan needed later – not shown)



Corrosion-proof rodent/bird screens for openings
(e.g., copper or stainless steel mesh)

Exception: clothes dryer vent

Sealed Sump Pump



Air Sealing



3. Pest Barriers

3.1 *Minimize pathways for pest entry by sealing penetrations and joints in and between foundation and exterior wall assemblies, with blocking materials, foam, and polyurethane caulk or equivalent.* In addition, sump pit covers shall be air-sealed (e.g., mechanically attached with full gasket seal or equivalent.)

Advisories:

1. Additional precautions in areas subject to “Heavy” termite infestation probability as identified by IRC Figure 301.2(6):

- Foundation walls should be solid concrete or masonry with top course of solid block, bond beam, or concrete-filled block; AND
- Interior concrete slabs should be constructed with 6 in. x 6 in. welded wire fabric or equivalent, and concrete walls with reinforcing rods to reduce cracking; AND
- Sill plates should be of preservative-treated wood.

2. Additional precautions in areas subject to “Very Heavy” termite infestation probability as identified by IRC Figure 301.2(6) (i.e., AL, FL, GA, LA, MS, SC, and parts of CA and TX):



Power Vented Water Heater



Direct-Vent Furnace



Specific Specification Guidance

5.2 Fireplaces and similar fuel burning appliances located in conditioned spaces shall be vented to the outdoors and supplied with adequate combustion and ventilation air according to manufacturers' installation instructions AND shall meet the following energy efficiency and emissions standards and restrictions:

- **Masonry fireplaces** are not permitted, with the exception of "masonry heaters" as defined by ASTM E1602, and the IBC, section 2112.1 (i.e., fireplaces engineered to store and release substantial portions of heat generated from a rapid burn).
- **Factory-built, wood-burning fireplaces** shall meet the certification requirements of UL 127, and meet the emission limits in EPA 40 CFR Part 60.
- **Natural gas and propane fireplaces** shall be power vented or direct vented, as defined by NFPA 54, section 3.3.108, have a permanently fixed glass front or gasketed door, and comply with ANSI Z21.88/CSA 2.33.
- **Wood stove and fireplace inserts** as defined in Section 3.8 of UL 1482, shall meet the certification requirements of that standard, and shall meet emission requirements of EPA 40 CFR Part 60 and WAC 173-433-100 (3).
- **Pellet stoves** shall meet the requirements of ASTM E1509.
- **Decorative gas logs** as defined in K.1.11 of NFPA 54 (National Fuel Gas Code) are not permitted.
- **Unvented combustion appliances** are not permitted, with the exception of kitchen-type cooking devices with exhaust ventilation meeting ASHRAE 62.2 (section 5).

Source Control: Combustion Pollutants Certified CO Alarms



CO Alarm



Combined CO
& Smoke Alarm



Enforceable policy in
Multi-family buildings

Source Control: Combustion Pollutants Attached Garage Isolation



EXHAUST FAN

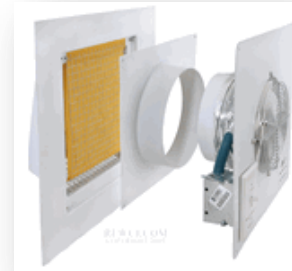

AIR SEALING & DOORS GASKETED

Source Control: Materials Low Formaldehyde Pressed Wood

MDF & Particleboard

Sample Industrial Board Bundle Tag For Particleboard
Certified to 0.20 PPM Standard. Tag Size 4"x5"

Designates
Standard
Reference
In Building
Code

**CONFORMS TO PARTICLEBOARD
FORMALDEHYDE EMISSION REQUIREMENTS
OF BOTH ANSI A208.1-1999, TABLE B
AND HUD 24 CFR 3280**

Grademark of
Certification
Agency



MILL 000
Mill Number

**COMPANY
LOCATION
PRODUCTION DATE/SHIFT**



Health Hazards of VOCs

VOLATILE Organic Compounds

Immediate

- Eye & Respiratory Tract Irritation
- Headaches
- Dizziness
- Visual Disorders
- Memory Impairment

Up to 6 years

- Eye, Nose, and Throat Irritation
- Headaches
- Loss of Coordination
- Nausea
- Damage to Liver, Kidney, and Central Nervous System
- Cancer



Interior paints and finishes, including 90% or more of such products applied to interior surfaces of homes, shall be certified low-VOC or no-VOC by one of the following:

- Green Seal Standard GS-11, OR
- Greenguard Certification for Paints and Coatings, OR
- Scientific Certification Systems (SCS) Standard EC-10.2-2007, Indoor Advantage Gold, OR
- Master Painters Institute (MPI) Green Performance Standards GPS-1 or GPS-2, OR
- A third-party low-emitting product list based on CA Section 01350, e.g., the CHPS List at chps.net/manual/lem_table.htm.

Carpets and carpet adhesives shall be labeled with, or ***otherwise documented as meeting, the Carpet & Rug Institute (CRI) Green Label Plus or Green Label testing program criteria.*** Carpet cushion (i.e., padding) shall similarly be certified to meet the CRI Green Label testing program criteria.

Zero Net-Energy Ready

Technical Specifications: Solar Ready

Solar Ready Requirement

Average Daily Solar Radiation Per Month

ANNUAL

Solar Ready Encouraged

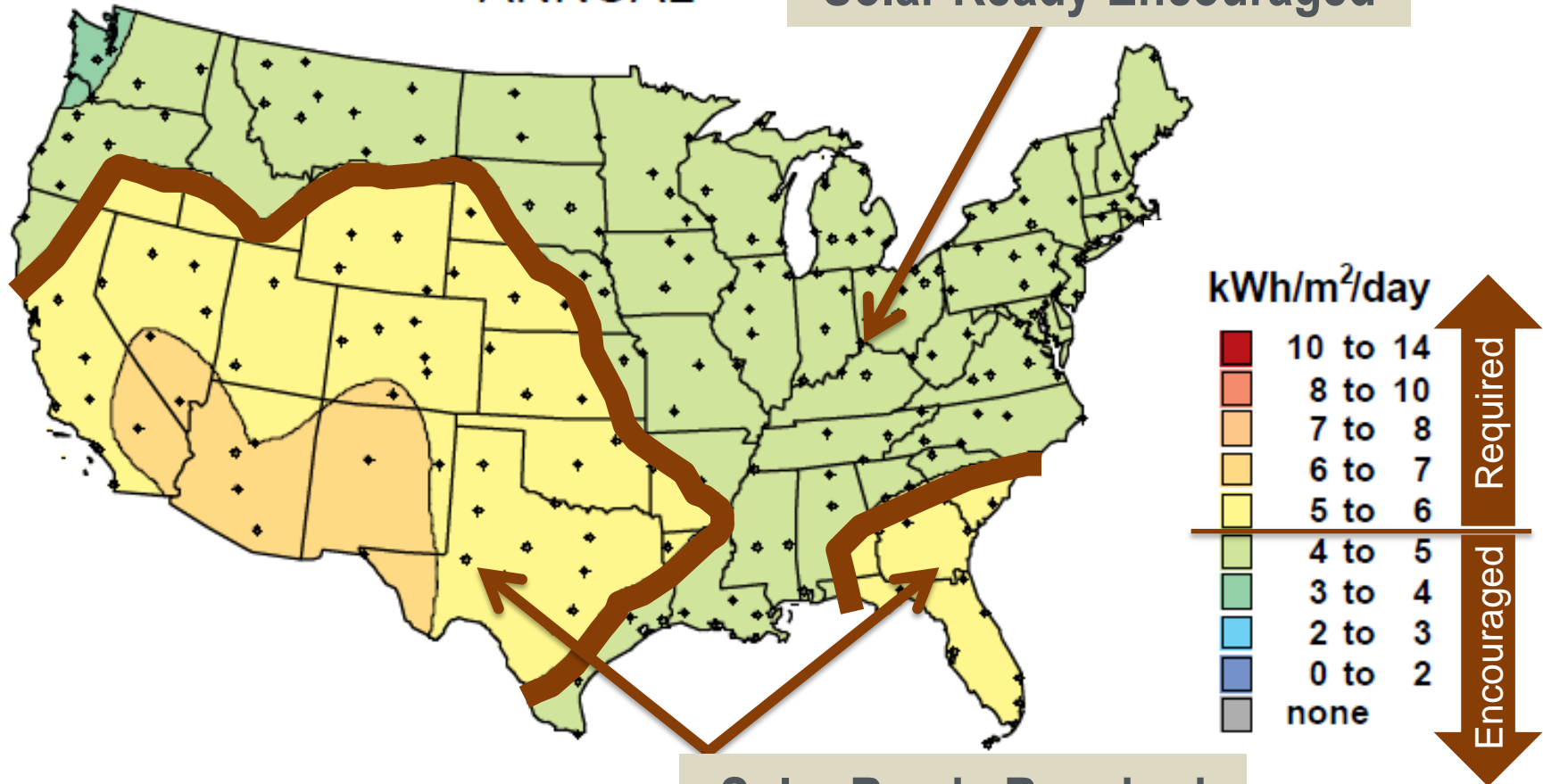

<http://www.energysavers.gov/pdfs/208.pdf>

Solar Ready Required

- **Renewable Energy Ready Checklists**
 - Determine applicability by zip code
 - http://gisatnrel.nrel.gov/PVWatts_Viewer/index.html
 - In this Mid-Atlantic example, solar resources = 4.8 kWh/m²/day



Provide code-compliant documentation of the maximum allowable dead load and live load ratings of the existing roof (Rec DL.: 6 lbs./sq. ft.)

Install conduit to run DC wire from roof to inverter

Dedicate area for installing inverter and balance of system

Install conduit to run AC wire from inverter location to electric panel

Designate and/or install circuit breaker for use by the PV system in the electric panel

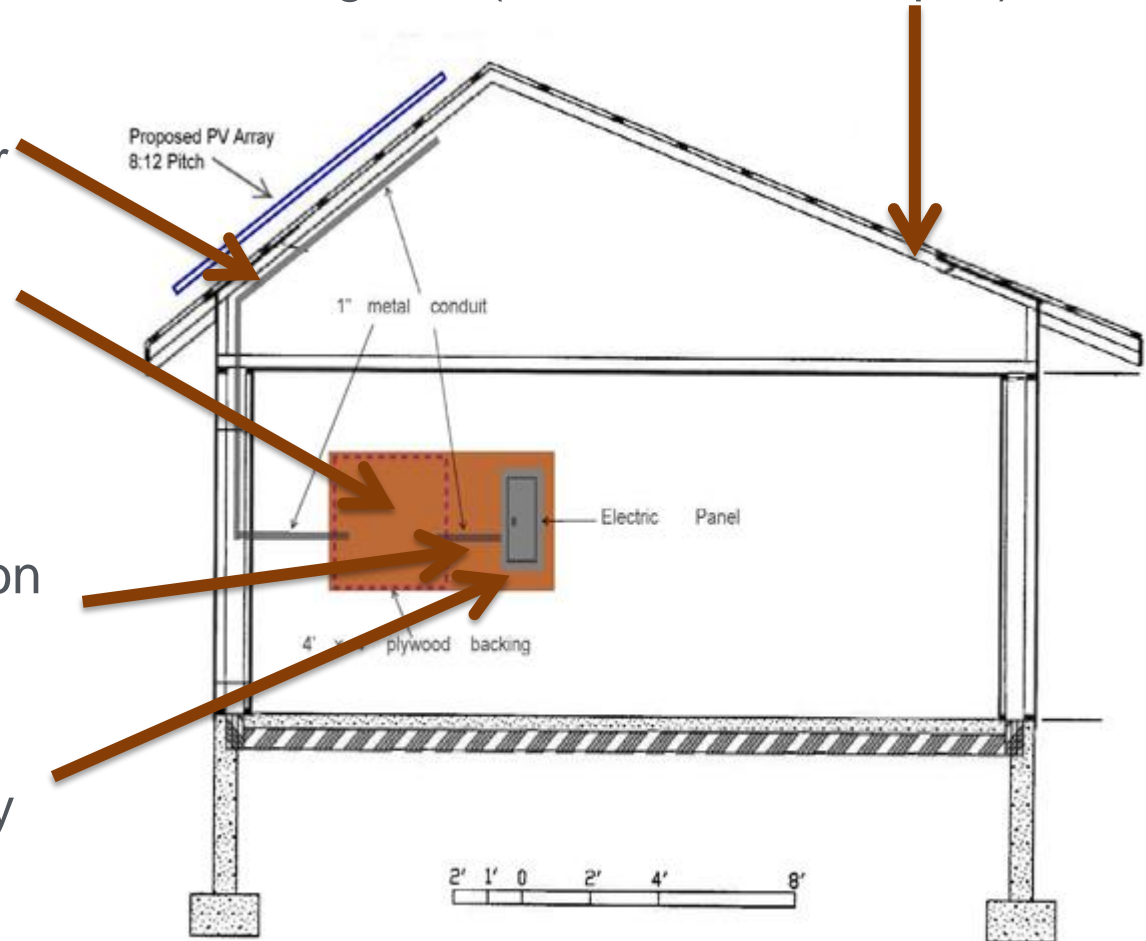

Install permanent roof anchor fall safety system on roof pitches greater than 3:12.



A roof anchor should be installed on a roof subsurface or vertical wall.

Dedicated Solar PV Plywood Panel



To make the house RE ready, the builders should dedicate and label an area for mounting an inverter and balance of system components.

With balance of PV system components installed on plywood panel.



Builders should reserve or install a dual pole circuit breaker in the electrical service panel for use by the PV system, in accordance with the National Electric Code.



Typical Construction



RERH Compliant

Solar Hot Water Ready Requirements

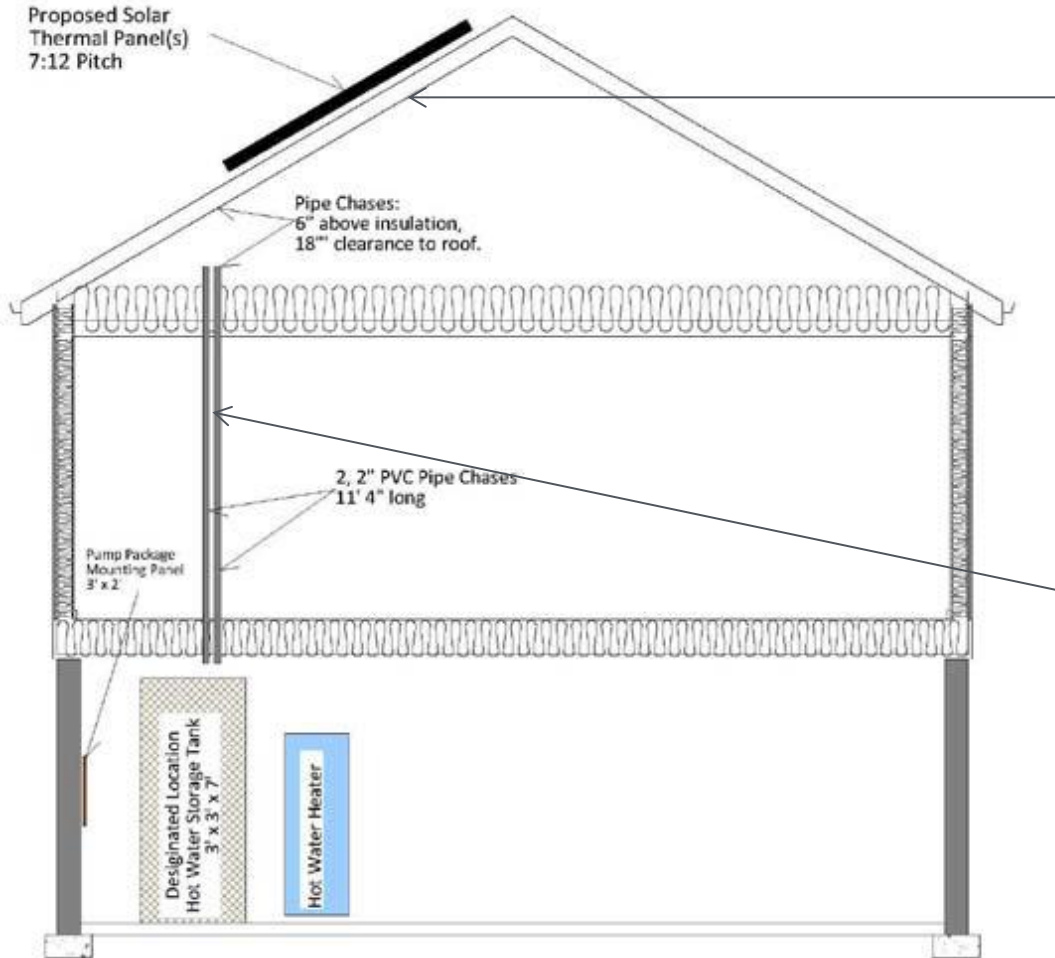

Provide code-compliant documentation of the maximum allowable dead load and live load ratings of the existing roof (Rec DL.: 6 lbs./sq. ft.)

Install a single 4" chase or 2-2" chases from utility room to the attic space below designated array location. Cap and label both ends.

Solar Hot Water Ready Requirements*

- * **Homes equipped with an ENERGY STAR whole-house tankless gas water heater or heat pump water heater are exempt from these requirements.**

Install a solar bypass valve on the cold water feed of the water heater (cap and label both ends).

Dedicate and label a 3' x 3' x 7' area in the utility room adjacent to the existing water heater for a solar hot water tank.

Dedicate and label a 3' x 2' plywood panel area adjacent to the solar hot water tank for the balance of system components/pumping package.

Install an electrical outlet within 6' of the designated wall area.

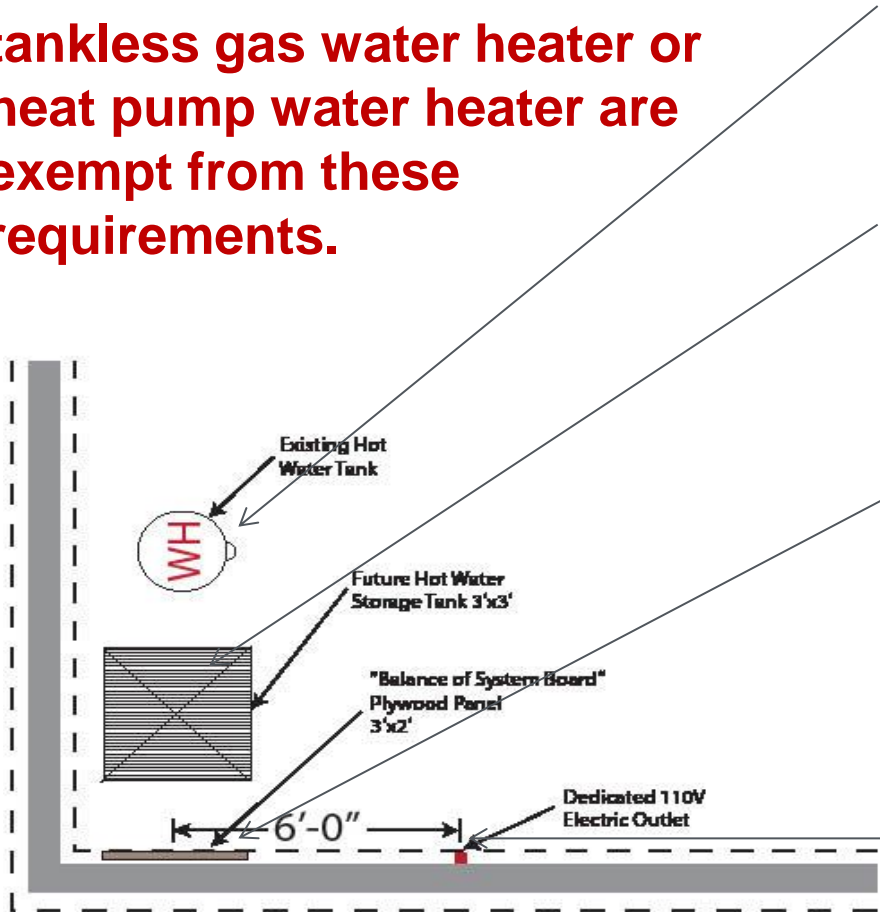

Solar Water Heating Only: Solar hot water storage tanks typically hold 80 to 120 gallons of water and weigh 800 lbs to 1,200 lbs when filled.

The builder should provide the homeowner with code-compliant documentation of the maximum dead weight load rating for all non-concrete floor assemblies in the designated location of the solar hot water storage tank.

Solar Water Heating Bypass Valve

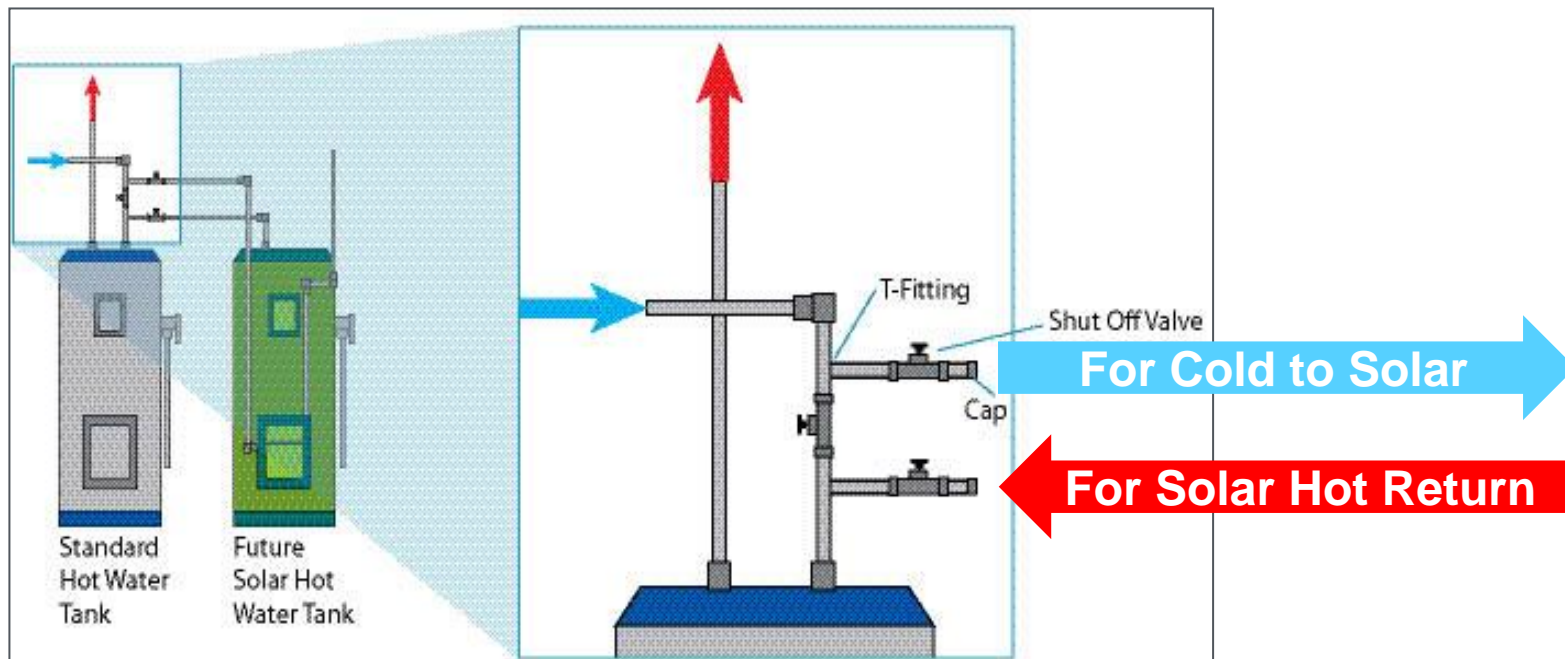

Above: The cold water feed of the existing water heater should have a code-compliant valve assembly installed to connect to the future solar storage tank. Solar bypass valve assembly includes shut-off valves on each of the stubbed and capped “T” fittings, and one shut off valve in the main pipe between the two “T” fittings.

Solar Water Heating Balance of System Components



Above: SWH infrastructure installed

Pictured is the final installation of the pump package into an area designated for the balance of system components.

Builders should dedicate and label a wall space of 3' x 2' adjacent to the solar hot water tank for this purpose.

A power source or wall outlet should also be installed within 6 feet of this area

- Same: ENERGY STAR Homes framework
- New:
 - Indoor airPLUS Checklist;
 - Renewable Energy Ready Home Checklists (where applicable)
 - Hot Water Distribution test
- Submissions:
 - Send “DOE Challenge Home Verification Summary” electronically to doechallengehome@newportpartnersllc.com
 - Otherwise builders will not receive “credit” on DCH website
 - Considering RESNET National Homes Registry for future

- Indoor airPLUS Checklist;
 - 1-page checklist
 - Builder or Rater may verify
 - Permissible methods:
 - Visual verification on site during construction
 - Reviewing photos taken during construction
 - Checking documentation
 - Equivalent methods as appropriate
 - Sampling permitted per RESNET-approved protocol

- Renewable Ready Checklists;
 - Follow checklists in RERH documents, ***but apply DOE Challenge Home exceptions***
 - **Revised checklist under development**

- Initiate operation of occupant-controlled or occupancy sensor-based recirculation systems, if present,
 - Let run for at least 40 seconds.
- Next, a bucket or flow measuring bag (pre-marked for 0.6 gallons) is placed under the hot water fixture.
- hot water turned on completely, a digital thermometer placed in the stream of water just where it meets the water being collected, and the starting temperature recorded.
- Once the water reaches the pre-marked line (approximately 24 seconds for a lavatory faucet), the water shall be turned off and the ending temperature reading at the same location recorded. The temperature must increase by 10 ° F.
- Only the fixture with the greatest stored volume between the fixture and the hot water source (or recirculation loop) needs to be tested.

U.S. DEPARTMENT OF **ENERGY** | Energy Efficiency & Renewable Energy

EERE Home | Programs & Offices | Consumer Information

Building Technologies Office

Building Technologies Office

SEARCH

Search Help ▶

HOME ABOUT **EMERGING TECHNOLOGIES** **RESIDENTIAL BUILDINGS** COMMERCIAL BUILDINGS APPLIANCE & EQUIPMENT STANDARDS BUILDING ENERGY CODES

EERE » [Building Technologies Office](#) » [Residential Buildings](#)

[Printable Version](#) [Share](#)

About

Take Action to Save Energy

Partner With DOE

Activities

- Solar Decathlon
- Building America
- Home Energy Score
- Home Performance with ENERGY STAR
- Better Buildings Neighborhood Program
- Challenge Home
 - Partner Log In
 - Become a Partner
 - **Criteria**
 - Partner Locator
 - Events
- Guidelines for Home Energy Professionals

Guidelines for Participating in the DOE Challenge Home

The DOE Challenge Home is a new and compelling way to recognize [builders](#) for their leadership in increasing energy efficiency, improving indoor air quality, and making homes zero net-energy ready.

The program builds upon the comprehensive building science requirements of ENERGY STAR® for Homes Version 3, along with proven [Building America](#) innovations and best practices. Other special attribute programs are incorporated to help builders reach unparalleled levels of performance with homes designed to last hundreds of years.

DOE Challenge Homes are verified by a qualified third-party and are at least 40%-50% more energy efficient than a typical new home. This generally corresponds to a [Home Energy Rating System \(HERS\) Index Score](#) in the low- to mid-50s, depending on the size of the home and region in which it is built.

[Take the Challenge today!](#)

Challenge Home Requirements

DOE Challenge Homes must meet all [DOE Challenge Home National Program Requirements](#) . They must:

- Comply with [ENERGY STAR for Homes Version 3 Requirements](#) for
 - Thermal Enclosure
 - HVAC Quality Installation (Contractor and HERS Rater)

Popular Residential Links

Success Stories

Tools

- EnergyPlus Whole Building Simulation Program
- Building Energy Software Tools Directory
- High Performance Buildings Database

Financial Opportunities

119

Thank You

Questions?

For More Information:

www.buildings.energy.gov/challenge/

e-mail Contact:

doechallengehome@newportpartnersllc.com

Zero Net-Energy Ready

Technical Specifications: Water Conservation

- **1950 – 2000:**
U.S. Population Doubled
Public Supply Water
Demand More than Tripled
- **Since 2011:**
> Half the U.S. with
Some Level of Drought.



U.S. Drought Monitor

July 31, 2012
Valid 7 a.m. EDT

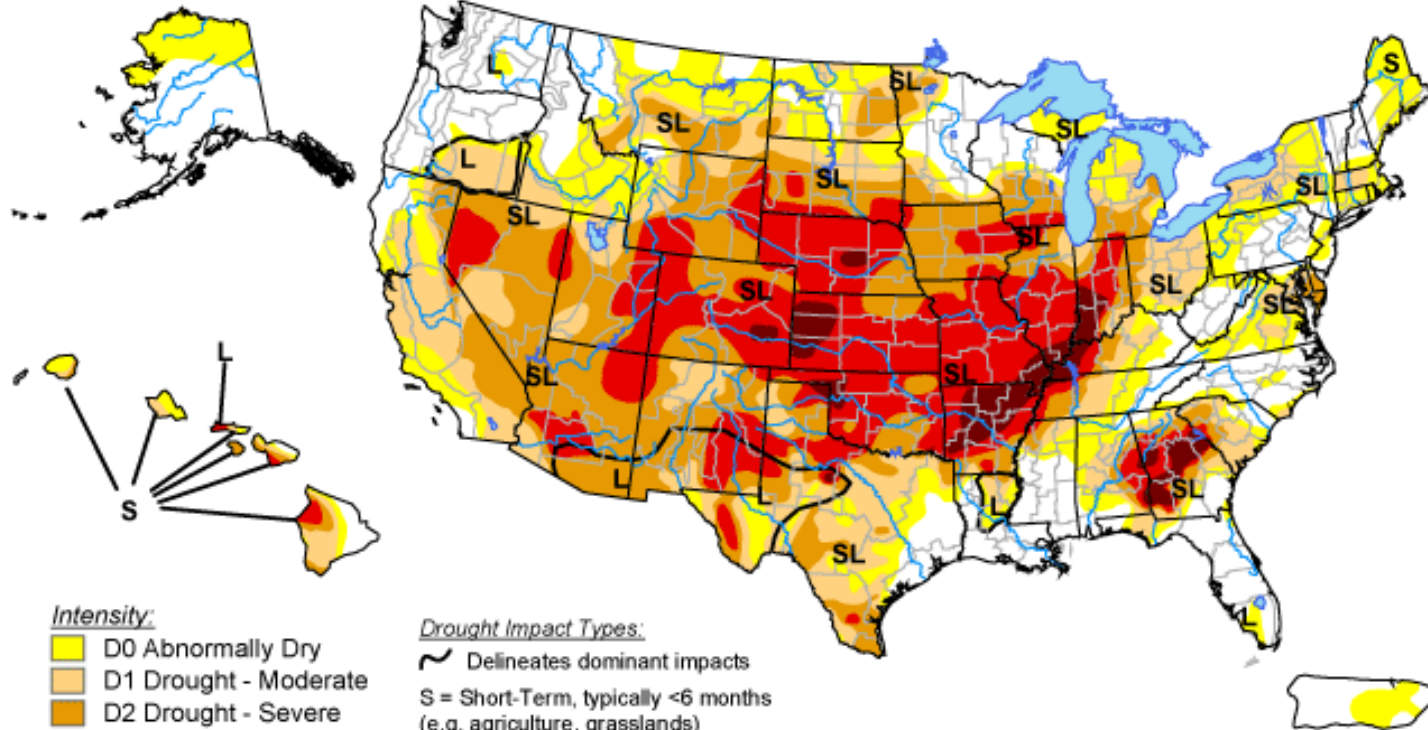

Intensity:

- D0 Abnormally Dry
- D1 Drought - Moderate
- D2 Drought - Severe
- D3 Drought - Extreme
- D4 Drought - Exceptional

Drought Impact Types:

- Delineates dominant impacts
- S = Short-Term, typically <6 months
(e.g. agriculture, grasslands)
- L = Long-Term, typically >6 months
(e.g. hydrology, ecology)

The Drought Monitor focuses on broad-scale conditions.
Local conditions may vary. See accompanying text summary
for forecast statements.

<http://droughtmonitor.unl.edu/>



Released Thursday, August 2, 2012

Author: Mark Svoboda, National Drought Mitigation Center

- More than 1.2 million homes were constructed in 2010 and 2011 in U.S.
- Average water use is 70% indoors, 30% outdoors.
- Outdoor use is higher in Southwest and other dry regions.
- 20% savings readily achievable

Residential Indoor Water Use

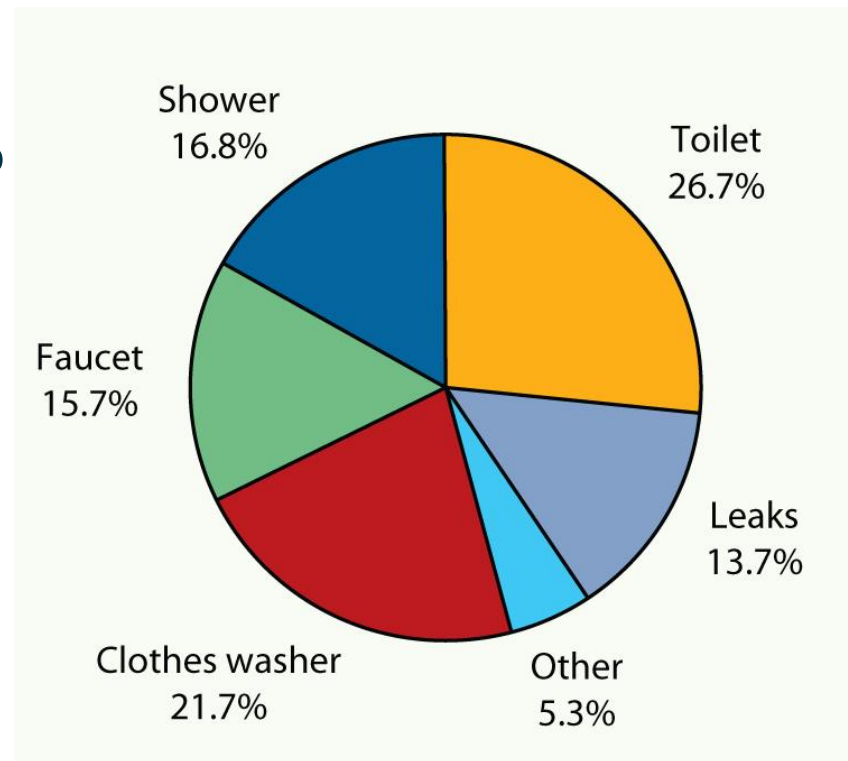

- **Indoor Fixtures**
 - Plumbing Fixtures
 - Appliances and Other Equipment
- **Distribution**
 - Service Pressure
 - Metering (for Multi-Family Homes)
 - Leak Prevention
 - Hot Water Distribution
- **Outdoor**
 - Landscape Design
 - Irrigation (if installed)

WaterSense Labeled Products



**Tank-Type
Toilets**
1,100 labeled
models



Lavatory Faucets
3,400 labeled models



Showerheads
600 labeled
models



Flushing Urinals
140 labeled models



**Irrigation
Controllers**
30 labeled models

**Labeled products are listed at:
www.epa.gov/watersense/products**

Built for when water was free and energy was cheap!

Copper L piping:

- 1" = 5.53 ounces/ft
- $\frac{3}{4}$ " = 3.22 ounces/ft
- $\frac{1}{2}$ " = 1.55 ounces/ft

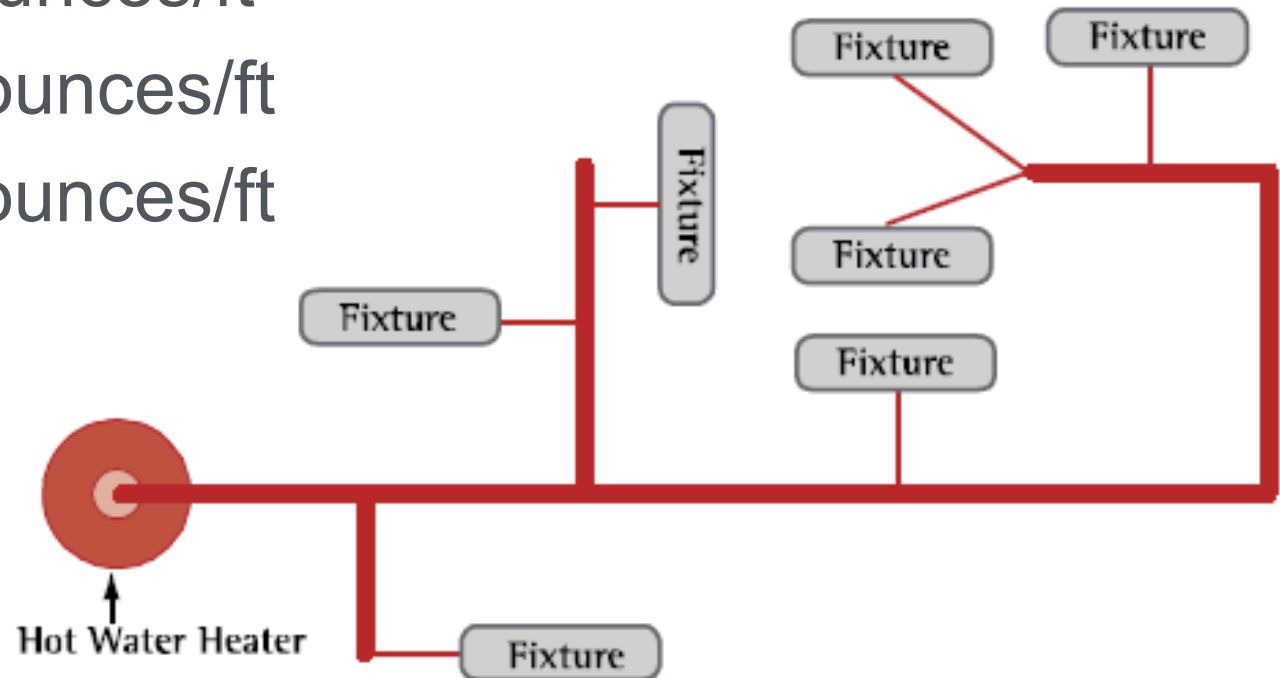

- *The system shall store no more than 0.5 gallons in any piping/manifold between the hot water source and any hot water fixture.*
- *No more than 0.6 gallons of water shall be collected from the fixture before hot water is delivered (accounts for water that must be removed from the system before hot water can be delivered).*
- *Recirculation systems must be demand initiated (push button or motion sensor).*
 - *Timer and temperature activated recirculation systems do not meet this requirement.*

All toilets shall be WaterSense labeled tank-type.

When the toilet tank fills, water should not flow over into this tube

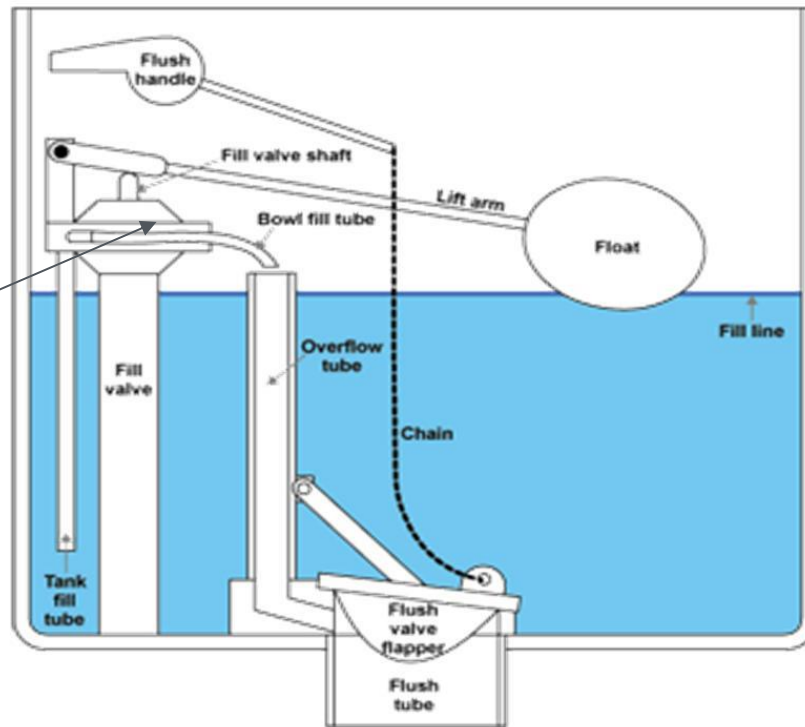

Angle valve



All bathroom sink faucets or faucet accessories (e.g., aerators) shall be WaterSense labeled.

Bathroom sink flow test



All kitchen sink faucets must have a maximum flow rate of 2.2 gpm.



Valve and connection hoses

Kitchen sink flow test



Shower compartment requirements:

- *The total allowable flow rate of water flowing at any given time from all showerheads must be limited to 2.0 gpm per 2,160 square inch (in²) increment or less of shower compartment floor area.*
- *Additional showerheads are allowed for each additional 2,160 in² floor area increment, provided the total flow rate from all flowing devices in each compartment is less than or equal to 2.0 gpm and the additional showerheads are operated by separate controls.*

Showerhead requirements:

- *All showerheads shall be WaterSense labeled.*
- *In cases where more than one showerhead or hand-held shower is provided in combination with others in a single device intended to be connected to a single shower outlet, the entire device must meet the maximum flow requirement in all possible operating modes.*



Showerhead flow test

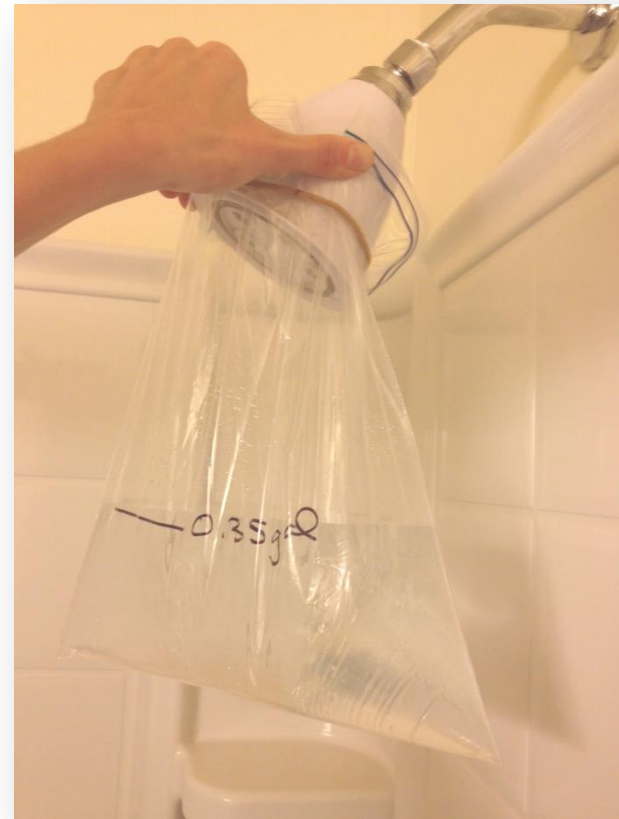

- *If a dishwasher is installed, it shall be ENERGY STAR[®] qualified.*
- *If clothes washer are installed, including those in common-use laundry rooms, they shall be ENERGY STAR qualified with a water factor (WF) ≤ 6.0 gallons per water cycle per cubic foot capacity.*

If an evaporative cooling system is installed, it must meet the following criteria:

- *Shall use a maximum of 3.5 gallons of water per ton hour of cooling when adjusted to maximum water use.*
- *Blowdown shall be based on the time of operation, not to exceed 3 times in 24 hours.*
- *Once-through or single-pass cooling systems, systems with continuous blowdown/bleedoff, and systems with timer-only mediated blow-down management do not meet the requirements.*



If a water softener is installed, it shall be certified to meet NSF/ANSI 44 including Section 7 voluntary requirements for efficiency rated systems, including:

- *Use demand-initiated regeneration controlled by a flow meter or water hardness sensor.*
- *Have a rated salt efficiency $\geq 3,350$ grains of total hardness exchanged per pound of salt (NaCl equivalency).*
- *Must not include devices that use a clock timer to set regeneration on a fixed time schedule.*
- *Must not regenerate using more than 5.0 gallons of water per 1,000 grains or hardness removed during the service cycle.*



- *If a drinking water treatment system is installed, it must be certified to meet applicable NSF/ANSI standards:*
 - *NSF/ANSI 42 Drinking Water Treatment Units – Aesthetic Effects*
 - *NSF/ANSI 53 Drinking Water Treatment Units – Health Effects*
 - *NSF/ANSI 55 Ultraviolet Microbiological Water Treatment Systems*
 - *NSF/ANSI 58 Reverse Osmosis Drinking Water Treatment Systems*
 - *NSF/ANSI 62 Drinking Water Distillation Systems*
- *Such systems shall yield at least 85 gallons of treated water for each 100 gallons of water processed (i.e., it shall have an efficiency rating equal to or greater than 85%).*

In multi-family buildings, each unit must be individually metered, submetered, or equipped with an alternate technology capable of tracking water use and making the information available to the residents of the individual unit.

WaterSense Water Budget applied to:

- Front Yard only for single-family homes
- All areas improved upon by the builder for single-family and multi-family buildings
- Temporary landscapes (e.g., straw over bare soil) may be installed if permanent landscapes cannot be installed due to climate conditions.

If an Irrigation System is installed, it must:

- Be designed or installed AND audited by a professional certified by WaterSense program
- Use fixed spray irrigation on turfgrass only and achieve at least a 65 percent distribution uniformity
- Use drip or micro irrigation on all plants other than turfgrass
- Include WaterSense labeled irrigation controllers or soil moisture sensors

Zero Net-Energy Ready

Technical Specifications: Disaster Resistance

- **Weather**
 - Wind
 - Hurricanes
 - Tornado/Hail
 - Severe Winter Storms
- **Natural Events**
 - Floods
 - Wildfires
 - Earthquakes
- **Pests**
 - Termites
 - General Pests

U.S. Disaster Map

Source: FEMA's National Emergency Management Information System

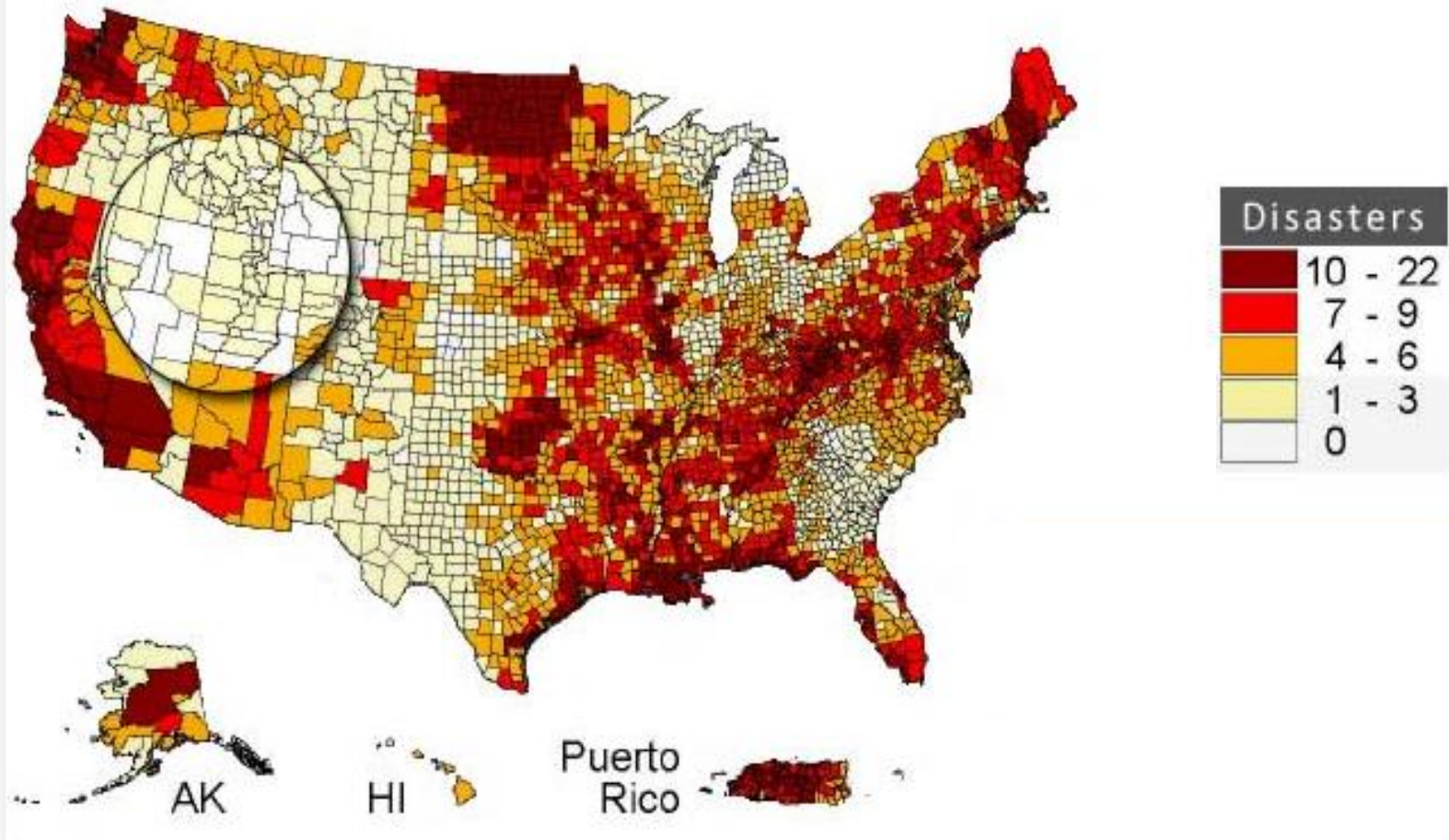

Disaster Risk in the U.S.

Lowest risk: Corvallis, Ore. Small quake and drought risk; little extreme weather.

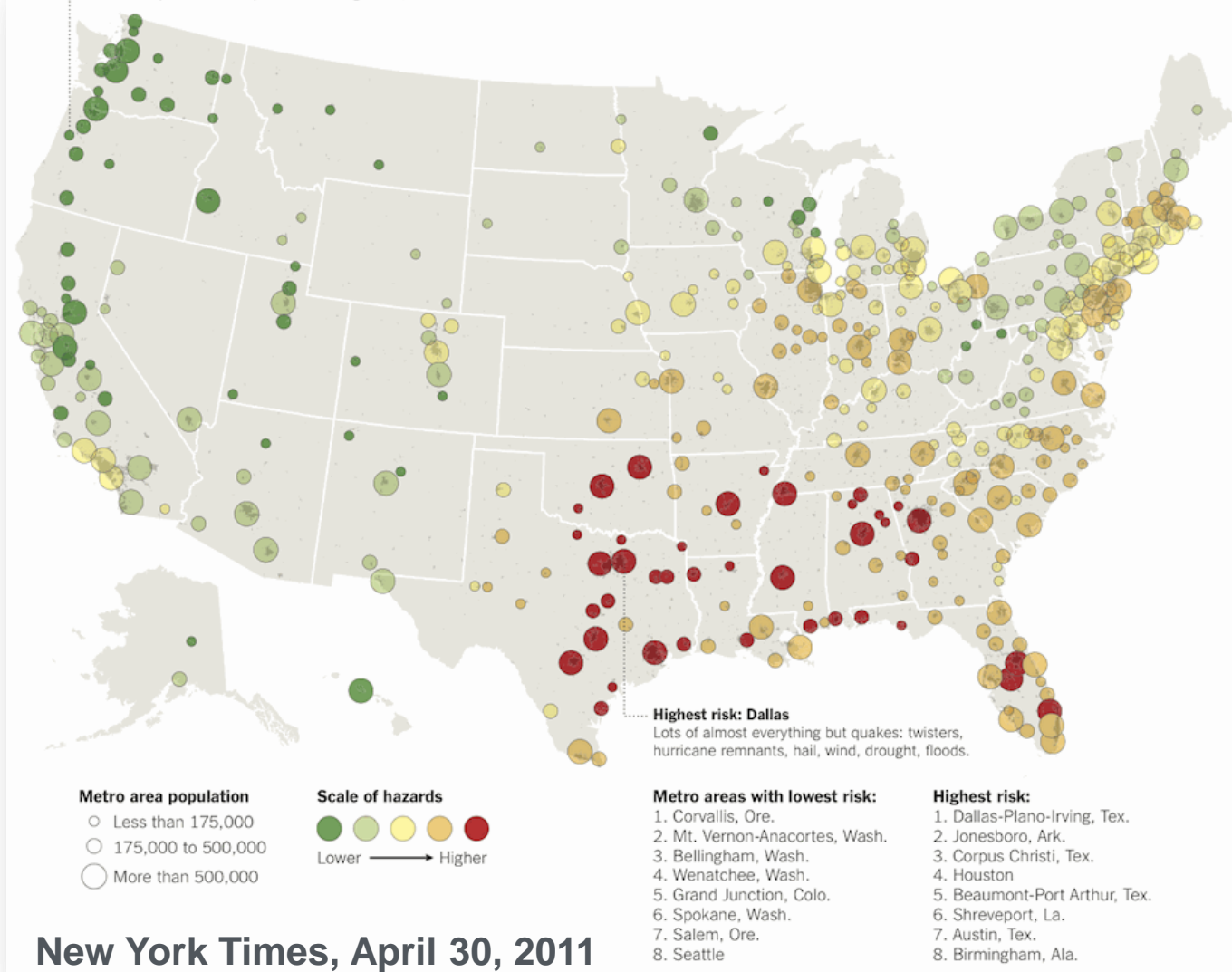

New York Times, April 30, 2011

Disaster Risk in the U.S.

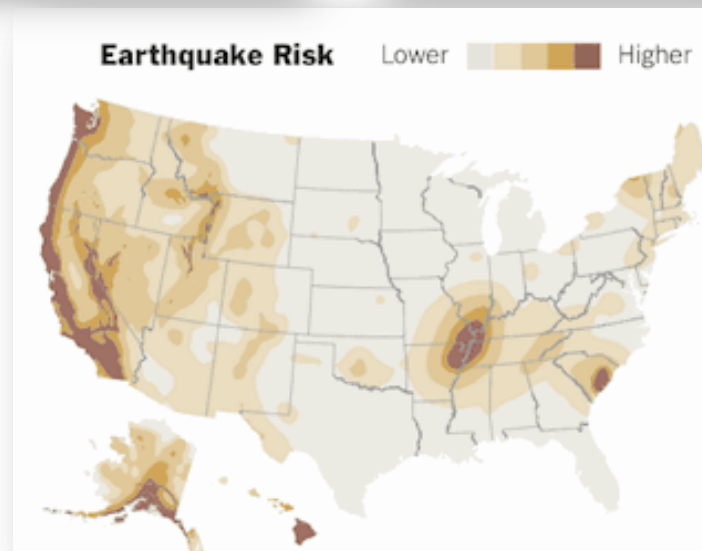
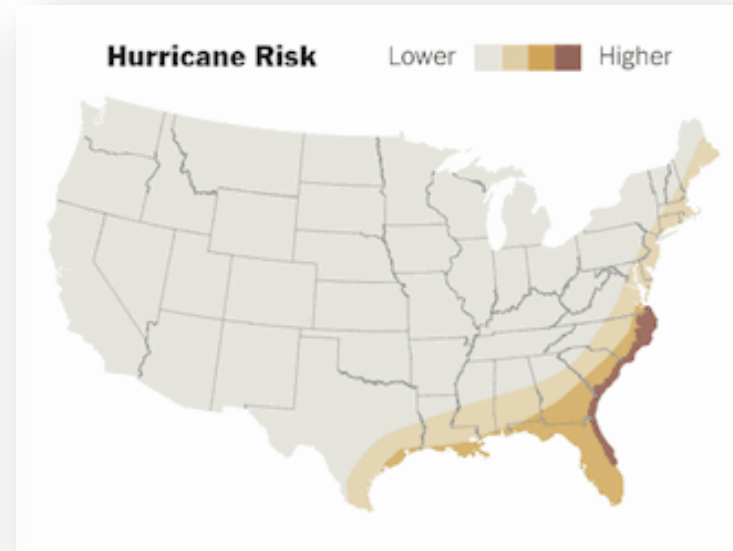
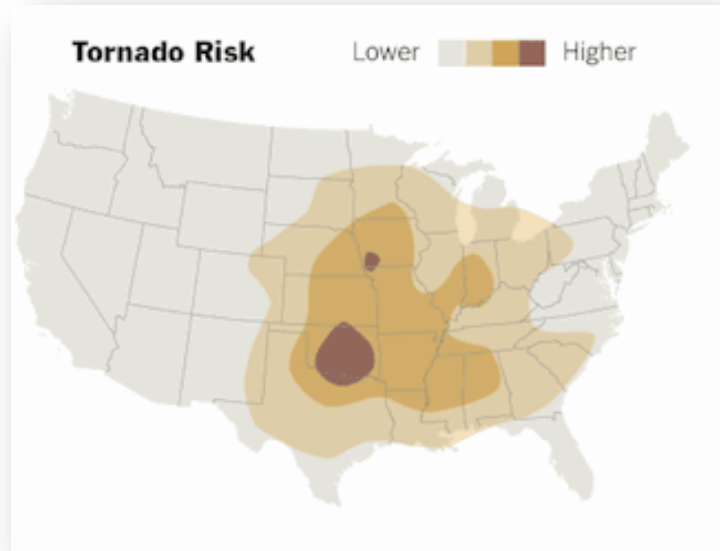

New York Times,
April 30, 2011

Weather: Wind, Hurricane, Tornado Risk Map

Fortified...for Safer Living Hurricane, High Wind, and Tornado/Hail Regions

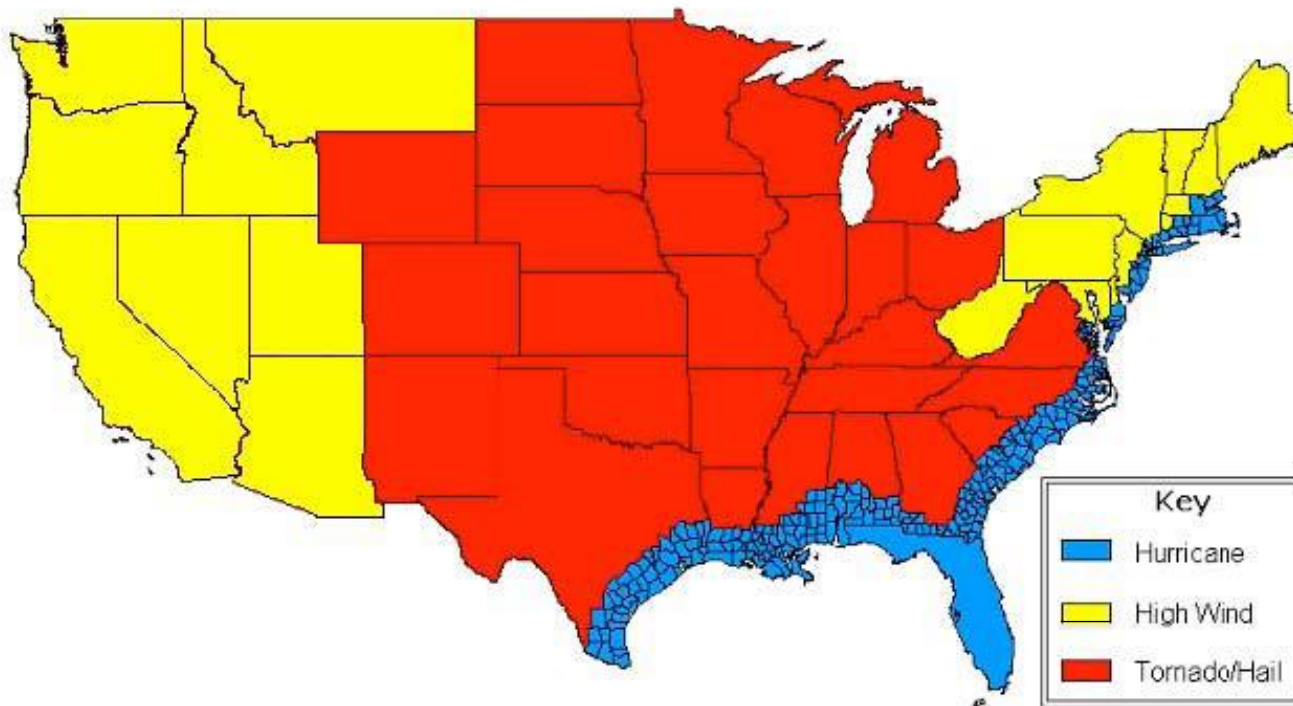

Weather: Tornado Risk Map

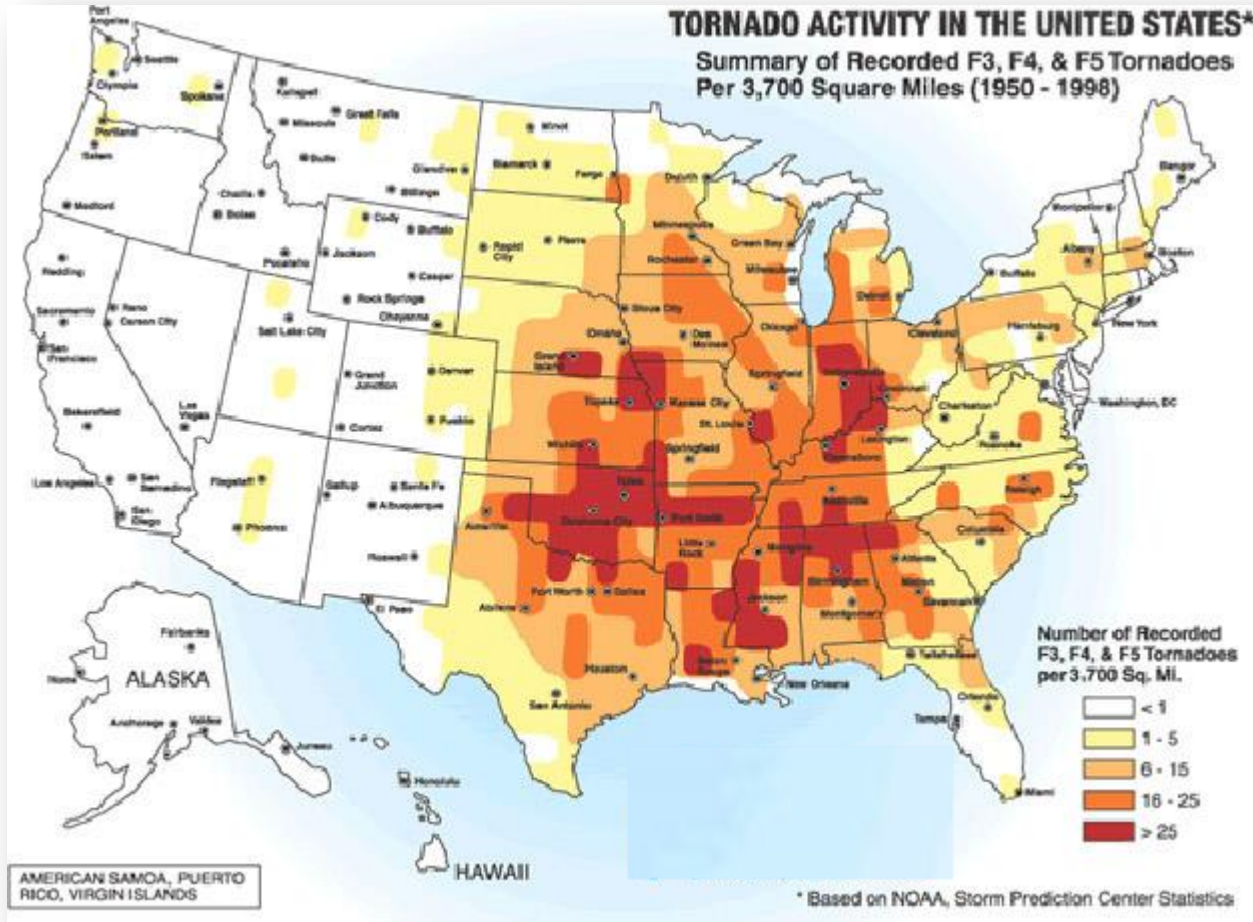

Weather: Hurricane Risk Map

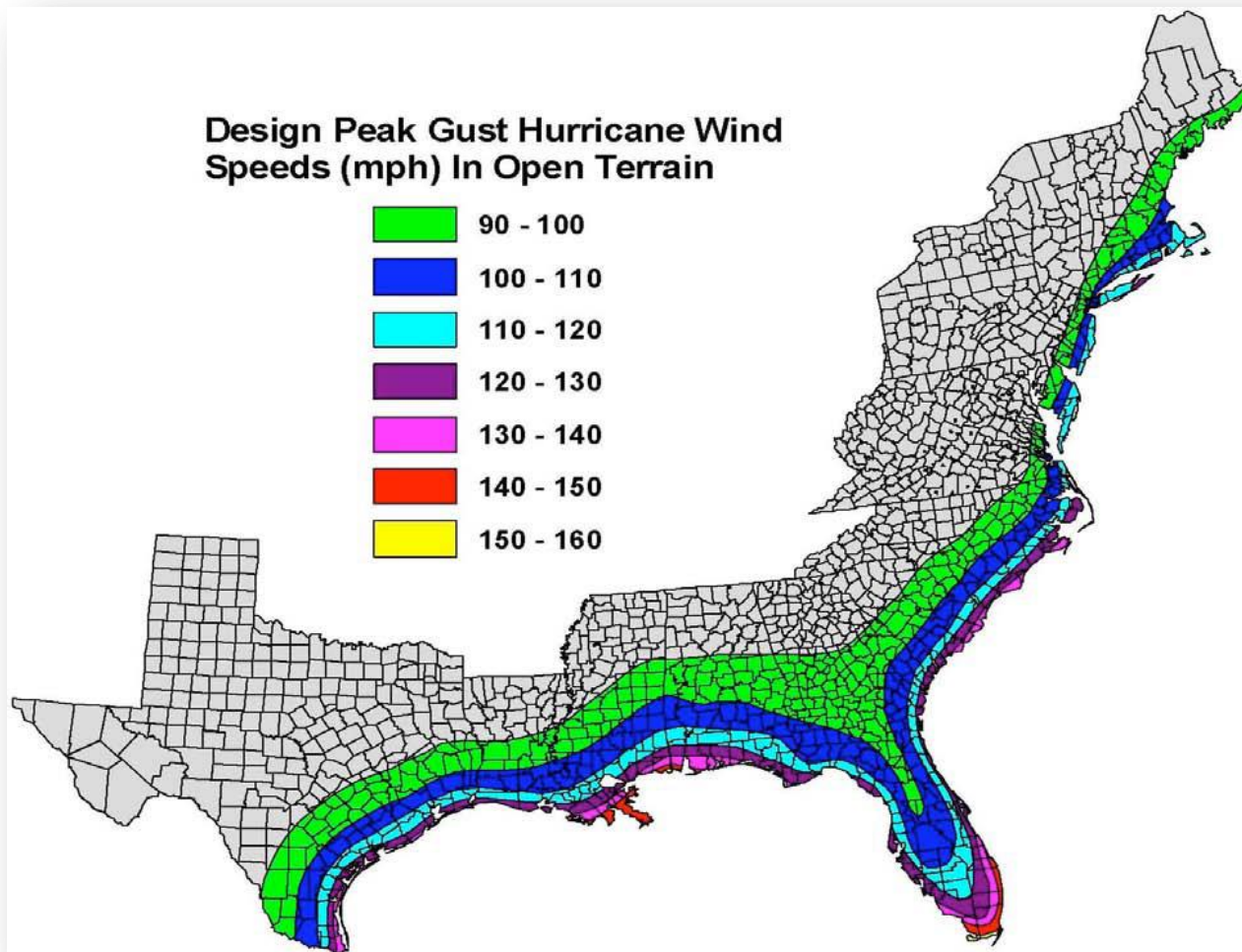

Weather: Wind Speed Requirements

Table 3-2: Adding 20 MPH to ASCE 7 basic wind speeds for FORTIFIED Design Wind Speed requirements (MPH)

ASCE 7 Wind Speed	Building Code Design Wind Speed (or interpolate between values)	FORTIFIED Design Wind Speed
< 90	90	110
90 - 100	100	120
100 – 110	110	130
110 – 120	120	140
120 – 130	130	150
130 – 140	140	160
140 – 150	150	170
> 150	150	170

One Requirement:

Install an impact resistant roofing

[UL 2218 Class 4 or FM 4473 Class 4 which is appropriate for flexible roofing products like asphalt shingles and metal panels or shingles]

A continuous load path in wood frame construction:

1. metal connectors between the rafters/trusses and the double top plate,
2. various systems involving connectors, sheathing, rods, hold-downs, etc to transfer loads from the top plate through the wall and into the foundation
3. properly designed and detailed foundations

A continuous load path in masonry construction:

1. metal connectors between the rafters/trusses and the bond/tie beam,
2. horizontal re-bar installed in the bond/tie beam,
3. vertical re-bar in fully grouted cells (number and location depends on design conditions) connecting to
4. horizontal steel in the footing/foundation (Figure 3-10)

Weather: Wind Continuous Load Path

Typical wall connections with stud spacing the same as truss/rafter spacing. Figure 305G-1, IBHS Guide

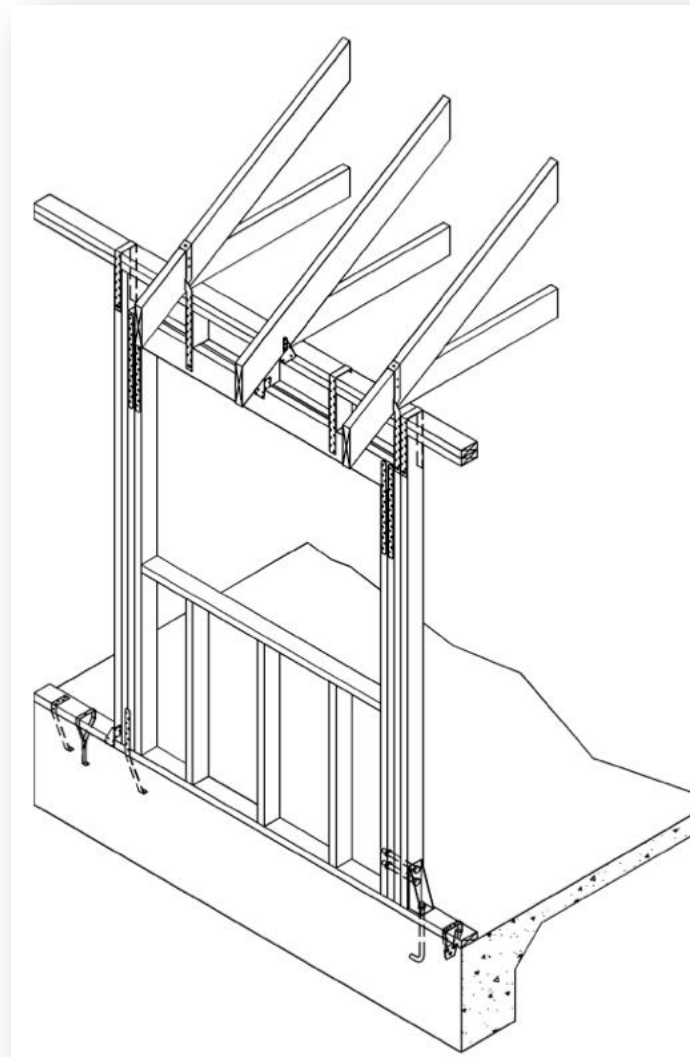

Installation of secondary water resistance using self-adhering strips.



Weather: Roof-Wall Connectors

Metal straps, clips, and connectors installed on the outside of the wall.

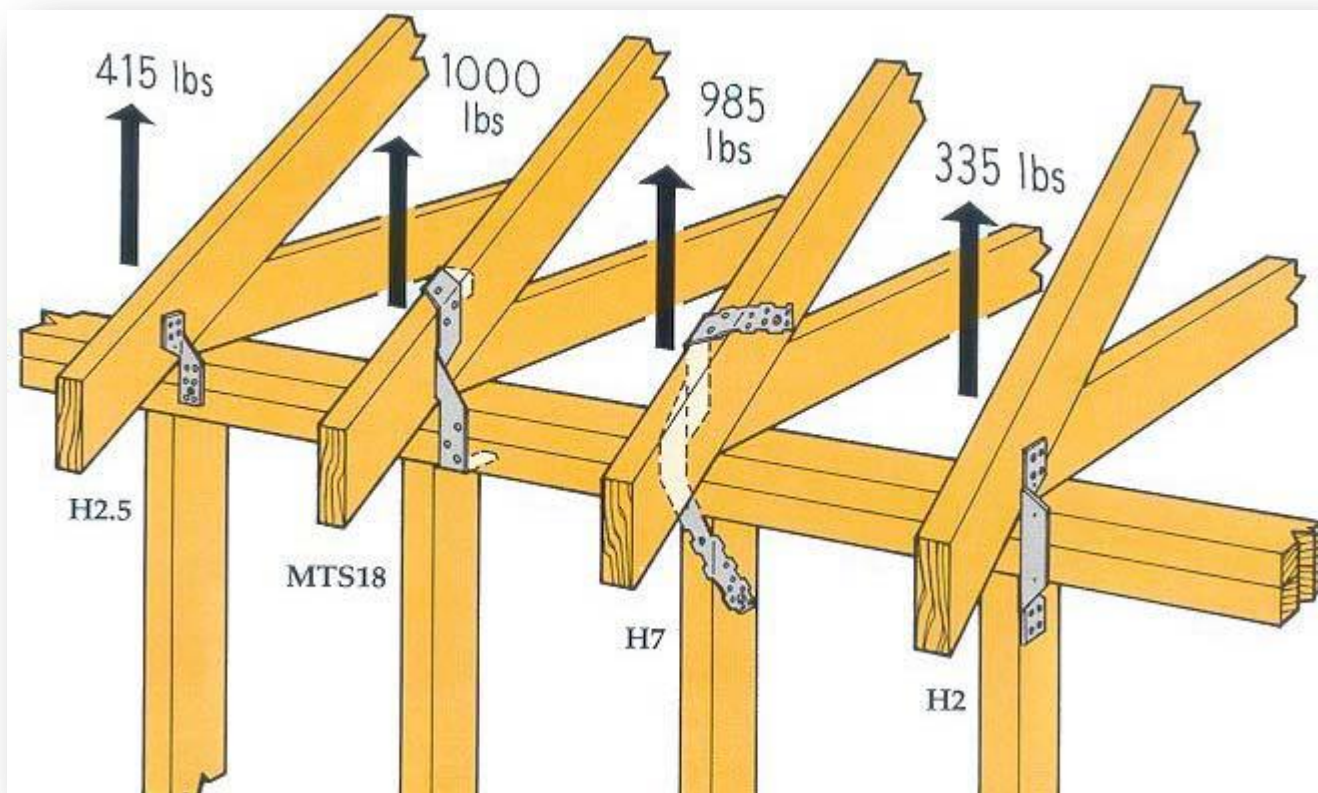

Metal straps, clips, and connectors installed on the inside of the wall.



Weather: Severe Winter Weather Risk Map

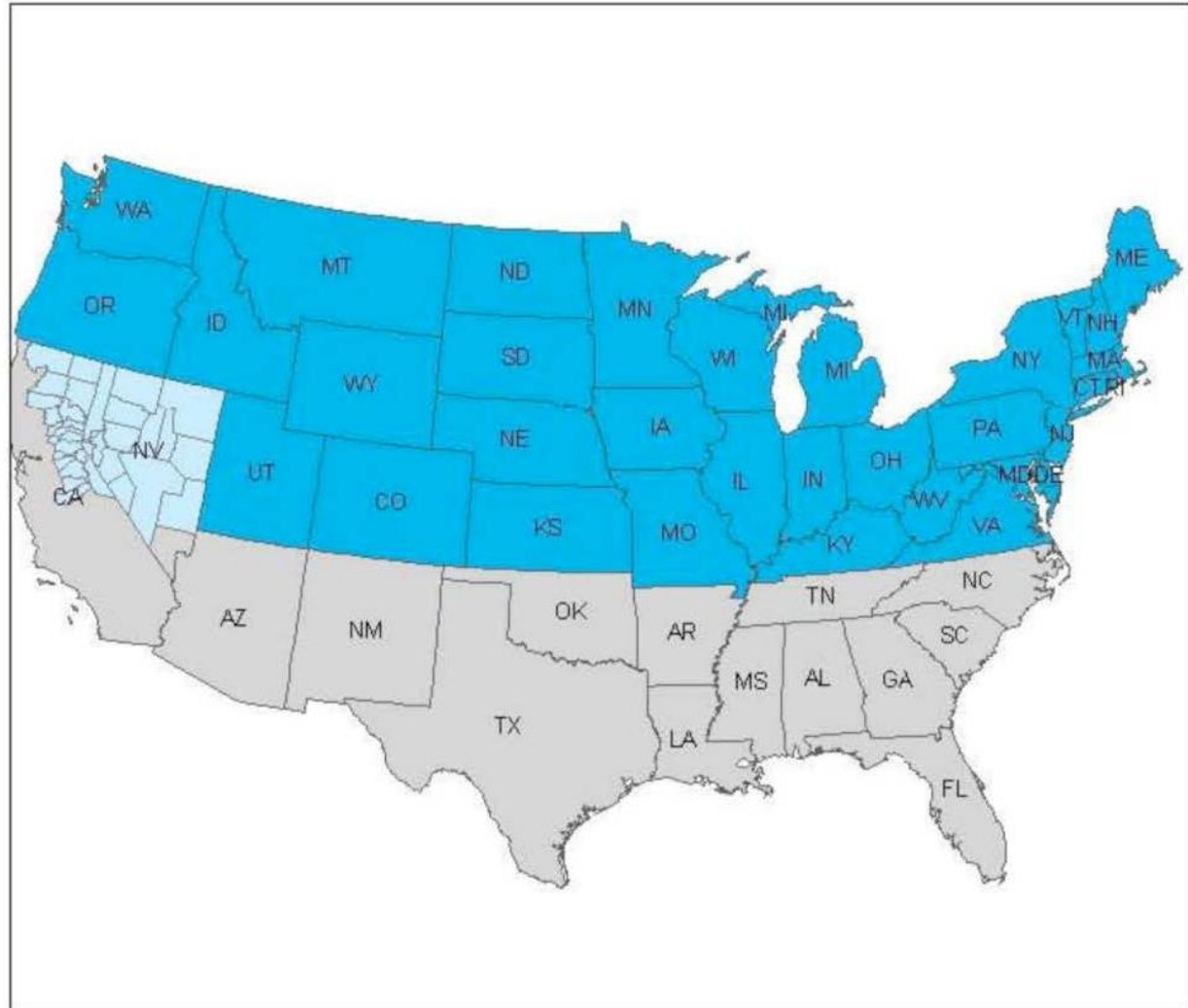

Legend

-  Applies to Entire State
-  Applies to County Only
-  Does Not Apply

- Addit. moisture barrier at roof eaves (ice flashing)
- Heating strips at drains on flat roofs
- No heat source installed in unconditioned attic
- No uninsulated recessed lights
- All attic access doors treated as exterior doors (insulated, sealed, and weather stripped/gasketed)
- All hidden attic penetrations (stack vents, partition walls, electric chases, etc.) properly sealed
- Sufficient insulation on piping in exterior assemblies or prohibit pipes in external assemblies or unheated spaces

Natural Events: Flood Risk Map

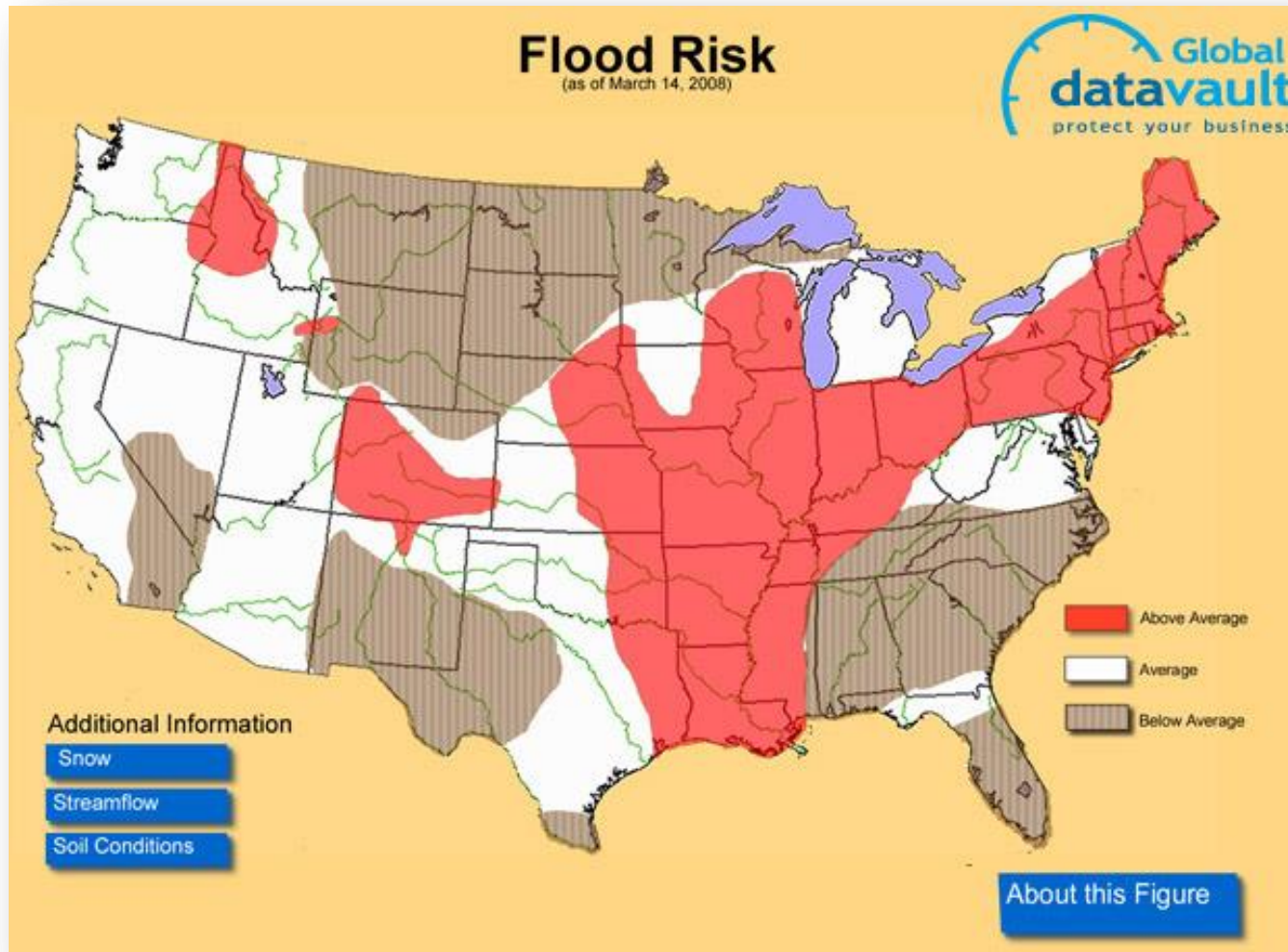

Minimum Requirements of the National Flood Insurance Program (NFIP) except:

- The building must be at least 3' higher than the BFE (Base Flood Elevation)
- The foundations in Coastal A zones must adhere to same requirements as those in V zones. That is, only open elevated foundations are allowed.

Natural Events: Flood Risk Management

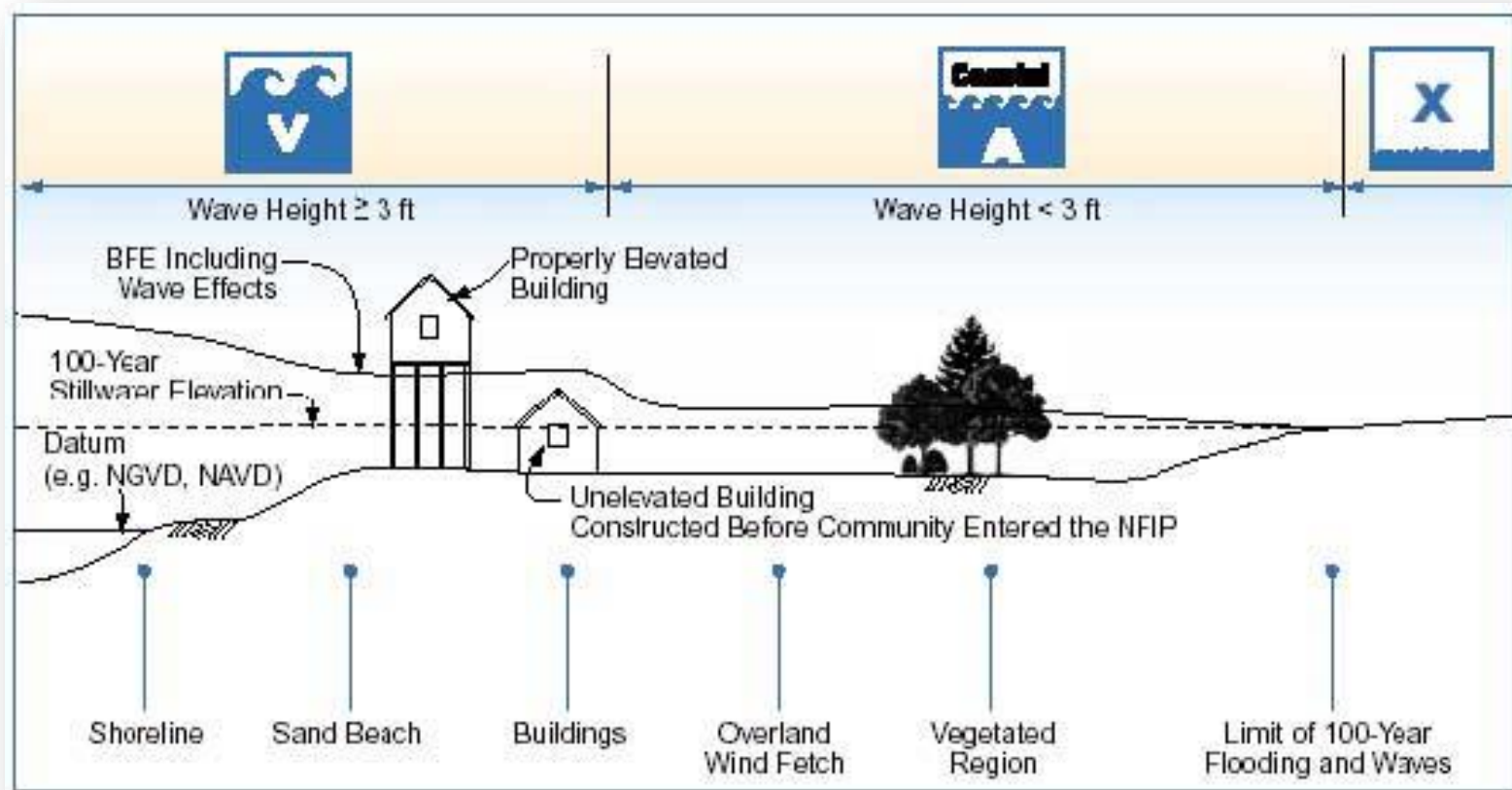

Typical shoreline elevation showing flood zones V, Coastal A and X (Coastal Construction Manual, 3rd edition, FEMA 55).

Natural Events: Wildfire Risk Map

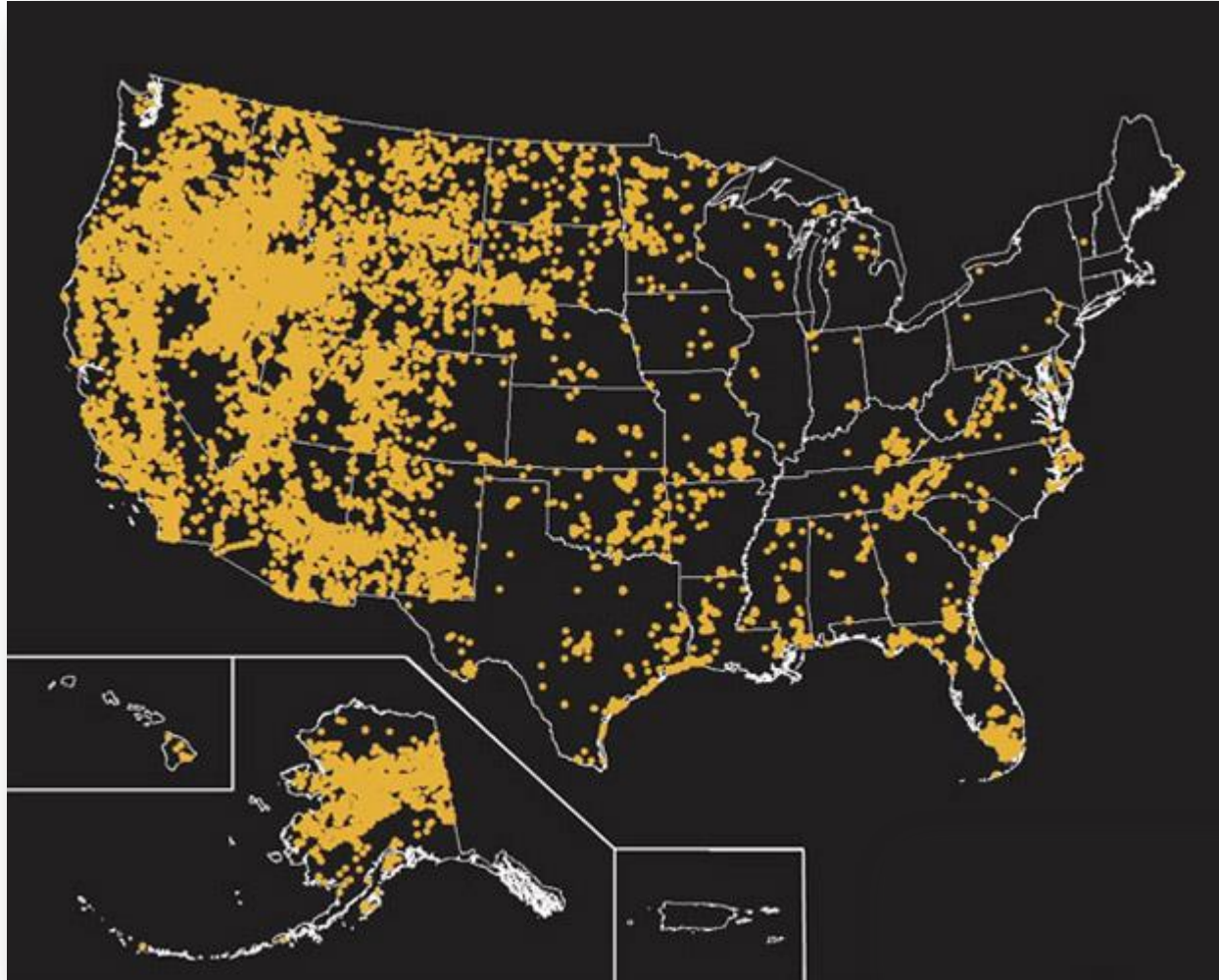

- Non-combustible street number at least 4' high
- Firewood Storage and LP Containers at least 50' away from home structure and at least 15' defensible space
- Non-combustible screening covering attic/sub-floor vents
- Gutters and downspouts of noncombustible materials
- Min. 12' wide driveways with min. 13.5' vertical clearance
- Gates must open inward and at least 2' wider than driveway
- Individual fire extinguishers
- Spark arrestors in all chimneys
- Defensible space that varies by hazard area classification
- Additional requirements base on hazard area classification (extreme, high, or moderate)

Defensible Space Varies:

- Extreme Hazard Area - 100'
- High Hazard Area - 50'
- Moderate Hazard Area - 30'

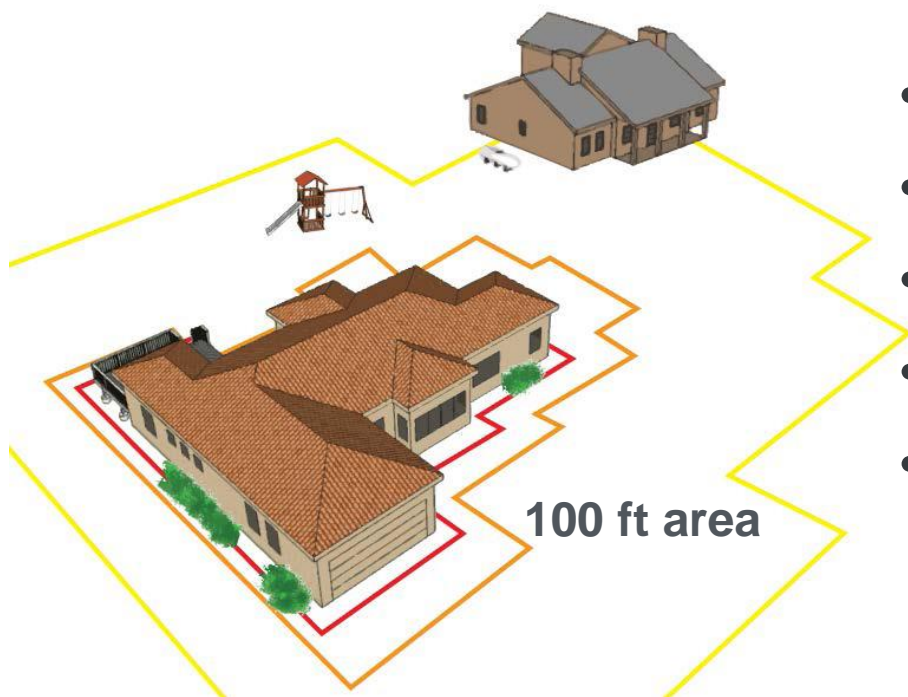

Defensible Space Characteristics:

- Grass mowed below 6"
- Regular Irrigation
- For trees >18', prune lower branches within 6' of ground
- Trees at least 10' apart
- No tree limbs within 10' of home
- All plants or plant groups >20' apart
- No vegetation under decks
- Remove all dead/dying vegetation

Combustible and Non-combustible Soffit Materials

Combustible

- Vinyl
- PVC
- Wood boards or panels less than or equal to 1/2" thick (including plywood and OSB)

Noncombustible

- Aluminum
- Wood boards or panels greater than 1/2" in thickness (including plywood and OSB)
- Cementitious soffit board

Wildfire Protection Criteria that Varies by Wildfire Hazard Level

Natural Events: Wildfire Spark Arrestors

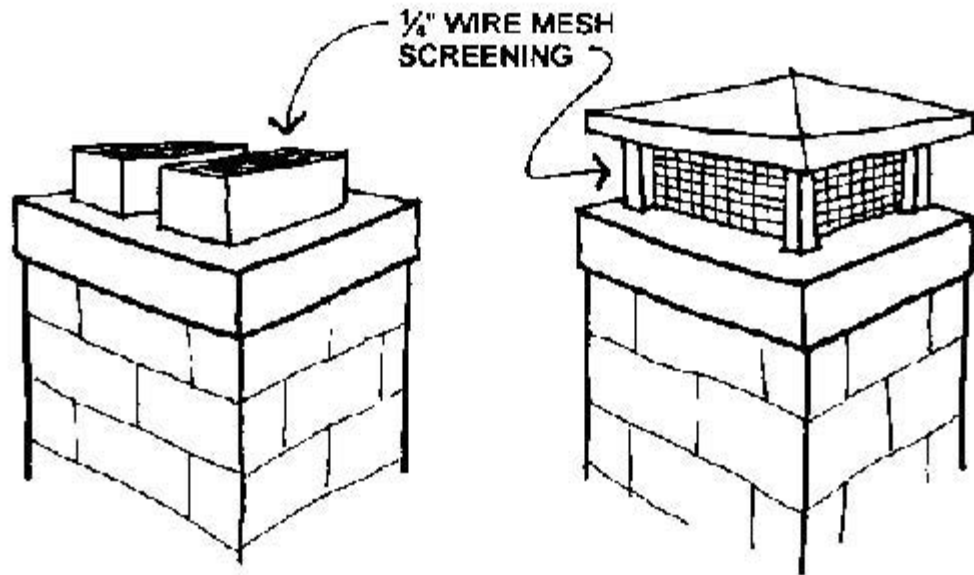

Spark Arrestor for chimney

Natural Events: Earthquake Risk Map

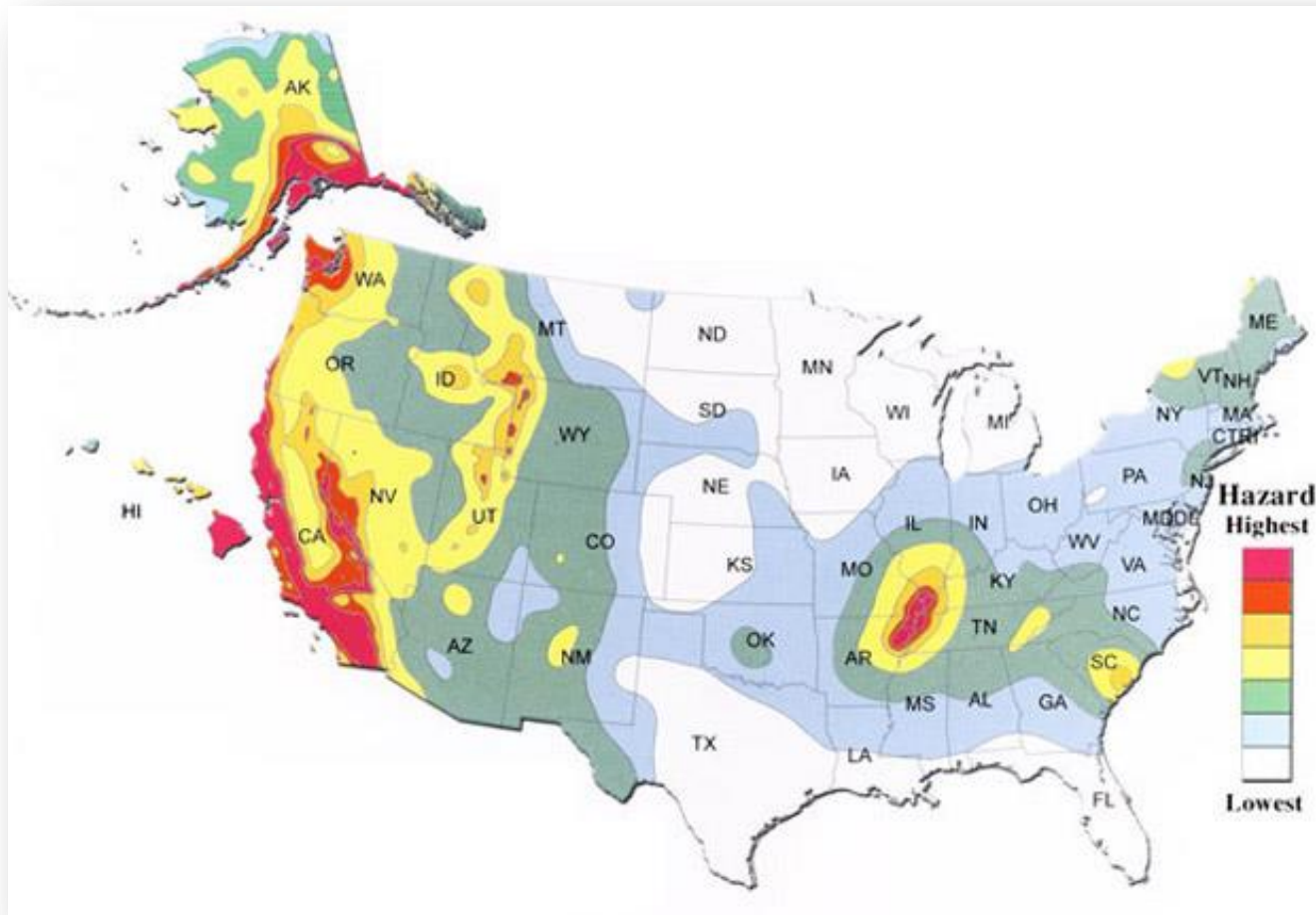

Natural Events: Earthquake Risk Map

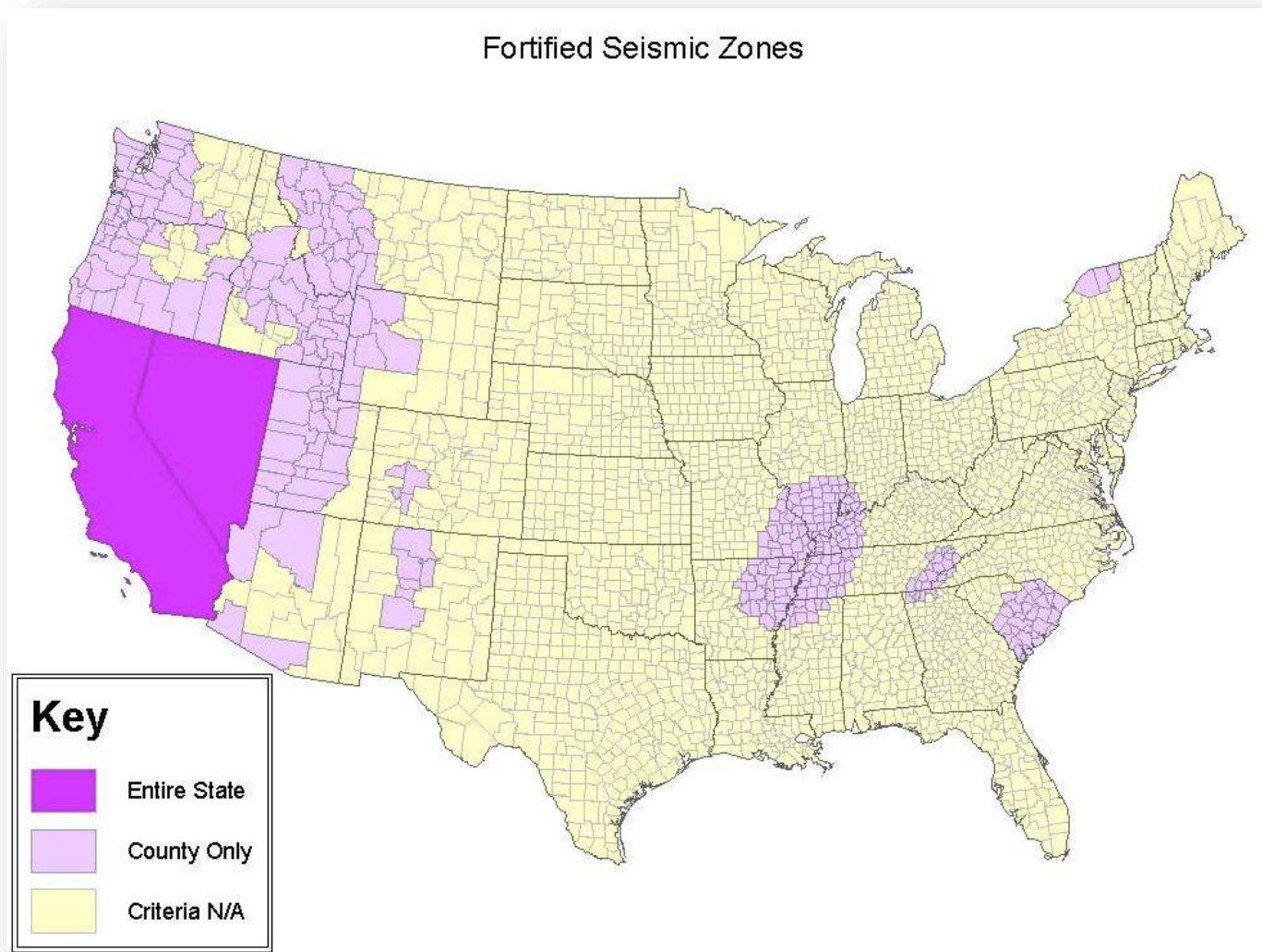

Pests: Termite Infestation Chart

U.S. Subterranean Termite Distribution

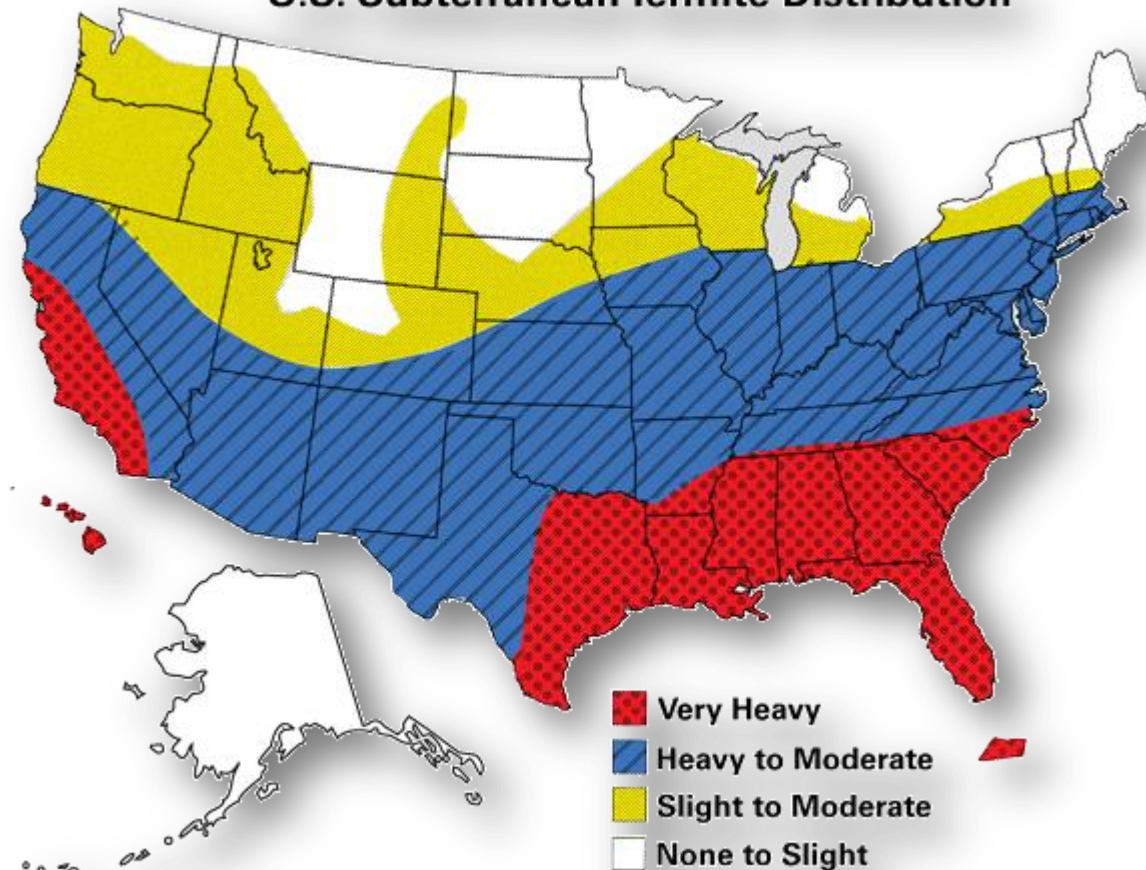

Note: Lines defining areas are approximate only. Local conditions may be more or less severe than indicated by the region classification.

- Termite Resistant Construction
 - Treated Wood Framing (e.g., Borate)
 - Steel Framing (but need to address thermal bridging)
 - Masonry Construction
- Pest Control
 - Air-Tight Construction
 - Screened Openings
 - Integrated Pest Management (IPM)

Zero Net-Energy Ready

Technical Specifications: Quality Management

1. Complete Construction Documents

- Qualify as Designed to Earn ENERGY STAR
- Document all Challenge Home specifications

2. Integrated Design Process

- Meet with all trades/rater early in the design process
- Document all meeting outcomes
- LEED for Homes Integrated Process Prerequisite complies

3. Formal Quality Management Program

- Written procedures and field checklists
- In-house inspections and field-test protocols
- Training requirements for staff and contractors

Zero Net-Energy Ready

Technical Specifications: Putting It All Together

Zero Net-Energy Ready System



Zero Net-Energy Ready Home

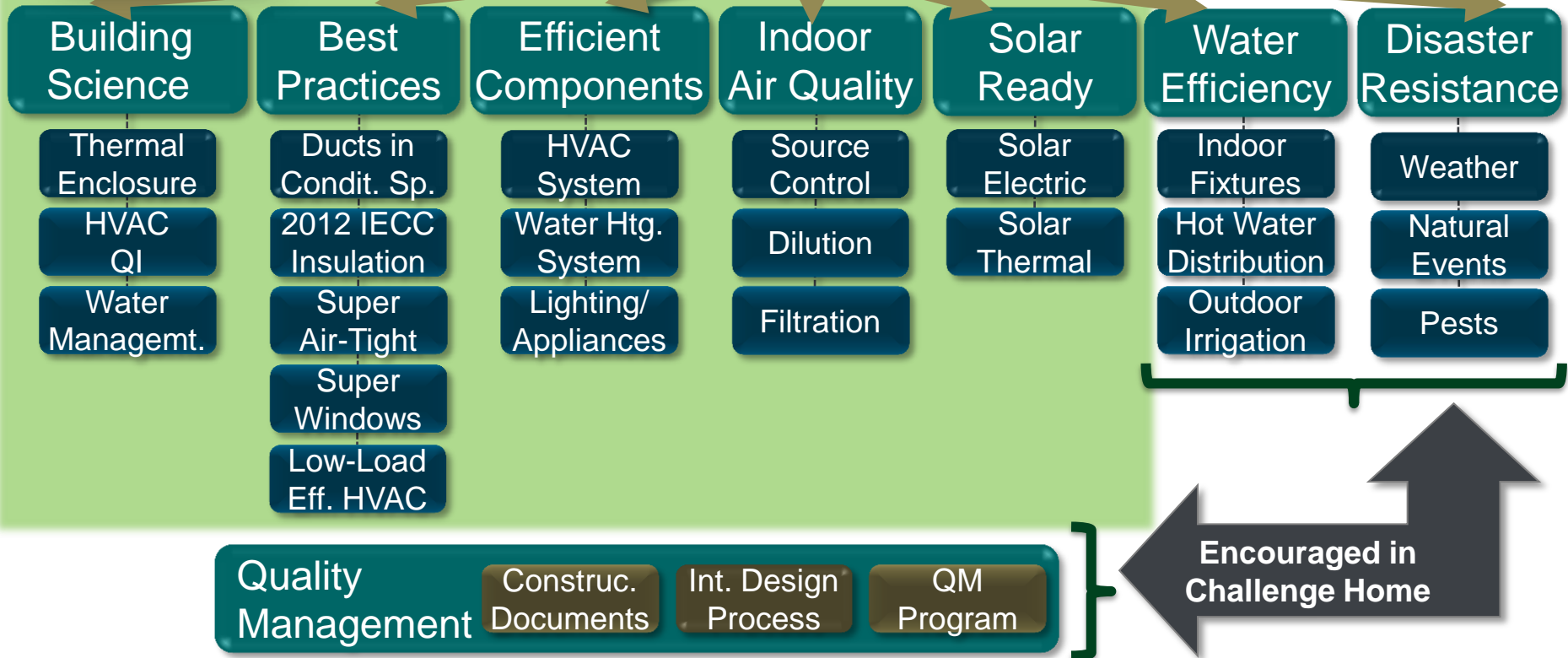

Zero Net-Energy Ready
**Recognition with
DOE Challenge Home**

You Have Lots of Choices...



- **Review**

- Technical Guidelines
- Partnership Agreement Terms

- **Register**

- Electronically Sign Agreement

- **Choose Optional Commitments:**



100% of homes meet DOE Challenge Home Guidelines



Homes meet EPA's WaterSense Guidelines



Homes meet IBHS's Fortified Home Guidelines



Meet DOE Challenge Home Quality Management Program

- **Resources**

- Customizable Homebuyer Brochures
- Case Studies
- Branding [Logos, Home Certificates and Labels]
- Electronic Newsletter [updates, policy changes, new innovations]

- **Technical Support**

- Building America Solution Center
- Building America Stakeholder Meetings
- Building America Research Studies

- **Recognition**

- DOE Housing Innovation Awards
- DOE Challenge Home Web Site Locator Tool

Links Buyers to Leading Edge Builders:

- Contact Information
- Optional Commitments



- # Labeled Homes
- Website link

For All Active Partners

DOE Challenge Home Partner Locator

Find out who is taking the challenge. Locate [DOE Challenge Home](#) partners near you! First choose a partner type and select a state. You can also enter a company name and find DOE Challenge Home partners that match your search.

Please note: Partners began registering for the new DOE CHALLENGE HOME on April 2, 2012. The locator will not produce large results of partners in the program for several weeks. Please check back to watch our progress.

Organization Type: Choose a State: [See Results](#)

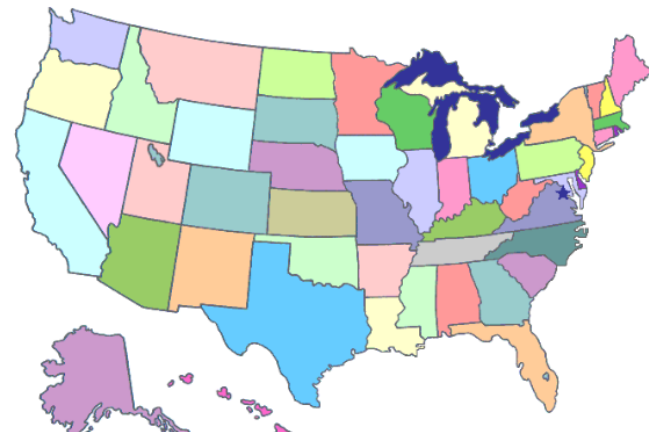

- **Take Orientation Training**
after registering and renew training every year
- **Provide Certificate**
for DOE Challenge Home to each home owner
- **Adhere to Brand Identity Guidelines**
for proper use of the DOE Challenge Home name and logo
- **Build/Verify at Least One Home/Year**
to maintain active partnership

To view the full Agreement terms and disclaimers, visit:

<http://www1.eere.energy.gov/buildings/challenge/>

- Update Company Information;
- Add, Delete, and Edit Contacts;
- Add/Update Your Logo;
- Add Commitments; and
- Access Key Tools and Resources

[\[http://www4.eere.energy.gov/buildings/challenge/my_account\]](http://www4.eere.energy.gov/buildings/challenge/my_account)

1. Plan Review:

Rater follows standard HERS rating process with additional checklists and requirements

2. Field Rating:

ENERGY STAR and Challenge Home can happen concurrently

3. Final Rating:

Rater confirms mandatory reqts. and Target Home HERS Index; then enters Builder Partner ID (found on builder profile) into HERS rating software (capability being developed)

4. Reporting:

Currently: Rater submits home certification to DOE

Future: Rater submits record per RESNET process with all DOE Challenge Home Certifications entered into the RESNET National Building Registry

- **Rater Prints Certificate** directly from rating software
- **Certificate Includes:**
 - Rating details
 - Graphic HERS Index
 - List of optional programs

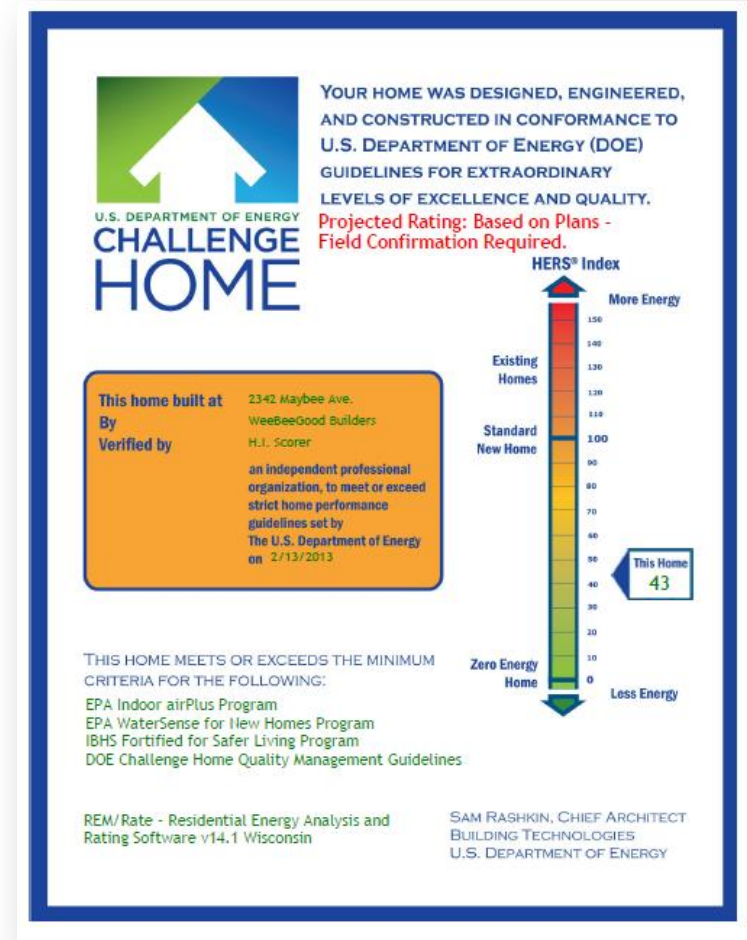

- **Case Study:**

Builder can opt to provide project information focused on marketing, business case, and technical innovations

- **Utility Bill Data:**

Home buyer can opt to provide billing data over one-year period.

- **‘Test Drive’ Challenge Home**
[1- 5 homes; most not ready for wholesale change]
- **Measure Profit Metrics:**
 - Call-Backs
 - Marketing Costs
 - Profit Margins
- **High-Performance Looks Different!**
 - Architectural Appearance
 - ‘Mark of Excellence’

Zero Net-Energy Ready **Local Solution**

Introduce Local HERS Raters

or

List of Local HERS Raters

Thank You

Questions?

For More Information:

<http://www1.eere.energy.gov/buildings/challenge/>

e-mail Contact:

doechallengehome@newportpartnersllc.com