

## **Justification and Background**

### **BSR/RESNET 301-2014, Addendum A-201x PD-02**

Hot water use and its attendant energy consumption are poorly represented by the procedures and calculations that are used for codes and standards and energy performance models. Much better data are now available from which hot water use and hot water energy consumption calculations may be computed. RESNET has been criticized by energy partner programs because its standards do not consider hot water distribution systems and advanced hot water technologies. Further, builder partners have expressed interest in additional opportunities to reduce energy use through smarter design and enhanced product choices.

#### **Hot Water Use Quantity (gallons per day)**

Parker and Lutz (2014) provide data on hot water use quantity in residences from which the procedures used in this addendum were developed. From their research, it is clear that the quantity of hot water use in residences is principally dependent on two factors: the temperature of the potable supply water entering the residence ( $T_{\text{mains}}$ ) and the number of occupants of the residence. The research indicates that the quantity of hot water used is dependent on the mixed water fixture temperature at which hot water is used ( $T_{\text{use}}$ ), from which a hot water mixing fraction ( $F_{\text{mix}}$ ) can be determined based on  $T_{\text{mains}}$ ,  $T_{\text{use}}$  and the set point temperature of the water heater ( $T_{\text{set}}$ ). The potable supply water temperature can be calculated using a sinusoidal equation developed by the National Renewable Energy Laboratory (Hendron 2008). The mixed water temperature at which water is typically used ( $T_{\text{use}}$ ) is assumed to be 105 °F. From field monitoring studies of 105 California homes Lutz and Melody report the median set point temperature of hot water heaters to be 123 °F. In a 1999 field monitoring study conducted in Central Florida, Parker (2014) found the median set point temperature to be 127 °F. It is the recommendation of the consensus committee that  $T_{\text{set}}$  be established as the average of these two field studies, or 125 °F. The mixing fraction is then determined using equation 1.

$$F_{\text{mix}} = 1 - ((T_{\text{set}} - T_{\text{use}}) / (T_{\text{set}} - T_{\text{mains}})) \quad \text{Eq. 1}$$

Parker and Lutz (2014) also report that the best estimate of hot water (HW) use in residences is estimated by equation 2.

$$\text{HW gallons per day (gpd)} = x + 19.8 (\text{Occupants} * F_{\text{mix}}) \quad \text{Eq. 2}$$

The 'x' in equation 2 is equal to the sum of the clothes washer (CWgpd) and dishwasher (DWgpd) hot water use, which is determined using the calculations provided by Section 4.2.2 of ANSI/RESNET 301-2014. However, examination of the data set used in the Parker and Lutz study to derive equation 2 showed that  $F_{\text{mix}}$  was calculated using a set point temperature of 120 °F rather than 125 °F. On recalculation of  $F_{\text{mix}}$  using a set point temperature of 125 °F, the regression coefficient for  $\text{Occupants} * F_{\text{mix}}$  is found to be 21.9 rather than 19.8.

Parker and Lutz (2014) further determined through regression analysis of 2009 RECS data for single family homes that the average number of occupants in residences is best estimated by equation 3.

$$\text{Occ} = 1.09 + 0.54 * \text{Nbr} \quad \text{Eq. 3}$$

Further, Klein (Roberts 2014) and Van Decker (Van Decker 2014) report that the average wasted water due to typical hot water distribution systems is approximately 20% of daily hot water use. This waste hot water is directly proportional to the number of occupant in the home, where homes with the fewest occupants experience the largest percentage wasted hot water and homes with the most occupants experience the smallest percentage wasted hot water. This occurs because more occupants result in greater instances of hot water use, which in turn results in less waste heat loss between hot water use events. Van Decker (2014a) has estimated that the range is linear from 24% for 1-occupant homes to 16% for 6-occupant homes.

From these findings, one can construct the data set shown in Table 2 for the average climate.

**Table 2 Sources of hot water use by number of bedrooms**

<b>Nbr</b>	<b>Occ</b>	<b>x</b>	<b>F<sub>mix</sub></b>	<b>HWgpd</b>	<b>%waste</b>	<b>Wgpd</b>	<b>Fgpd</b>	<b>Ifrac</b>
1	1.63	5.4	0.676	30.0	23.0%	6.90	17.66	0.575
2	2.17	6.8	0.676	39.2	22.1%	8.68	23.74	0.590
3	2.71	8.2	0.676	48.3	21.3%	10.27	29.87	0.601
4	3.25	9.5	0.676	57.3	20.4%	11.68	36.04	0.612
5	3.79	10.9	0.676	66.1	19.6%	12.91	42.26	0.621
6	4.33	12.3	0.676	74.7	18.7%	13.96	48.52	0.629
7	4.87	13.6	0.676	83.3	17.9%	14.83	54.82	0.637
8	5.41	15.0	0.676	91.7	17.0%	15.53	61.14	0.645
9	5.95	16.4	0.676	99.9	16.2%	16.07	67.50	0.653
10	6.49	17.7	0.676	108.0	15.3%	16.44	73.88	0.660

The highlighted row represents the “typical” residence

where

Nbr = number of bedrooms

Occ = number of occupants

x = Clothes washer plus dishwasher gallons per day

F<sub>mix</sub> = for average climate with average annual air temperature of 56.8 °F

HWgpd = total hot water gallons per day

Wgpd = wasted hot water gallons per day

Fgpd = HWgpd – Wgpd – x = fixture hot water gallons per day

and where

Ifrac = 0.90 \* Fgpd / HWgpd = the impact fraction of a drain water heat recovery system

The fixture and waste water data may be climate-normalized by dividing each of the gallons per day by F<sub>mix</sub>, resulting in the data set shown in Table 3.

**Table 3 Climate normalized sources of hot water use by number of bedrooms**

Nbr	Occ	x	nWgpd	nFgpd
1	1.63	5.4	10.2	26.1
2	2.17	6.8	12.8	35.1
3	2.71	8.2	15.2	44.2
4	3.25	9.5	17.3	53.3
5	3.79	10.9	19.1	62.5
6	4.33	12.3	20.6	71.7
7	4.87	13.6	21.9	81.0
8	5.41	15.0	23.0	90.4
9	5.95	16.4	23.8	99.8
10	6.49	17.7	24.3	109.2

These climate normalized data can then be regressed to determine a reference condition for hot water distribution systems in standard homes exclusive of  $F_{mix}$  (i.e. where  $F_{mix} = 1.00$ ), Figures 1 and 2 provide these regressions.

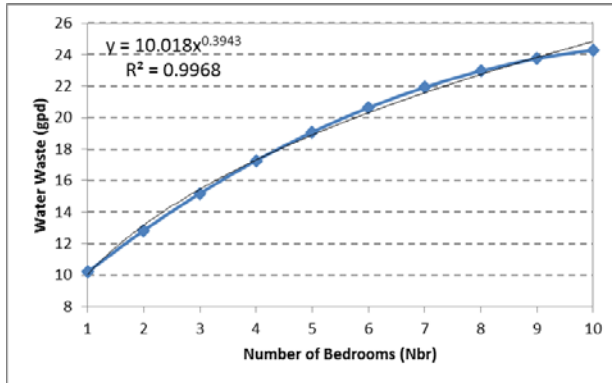

**Figure 1: Normalized wasted hot water use in residences due to distribution system losses**

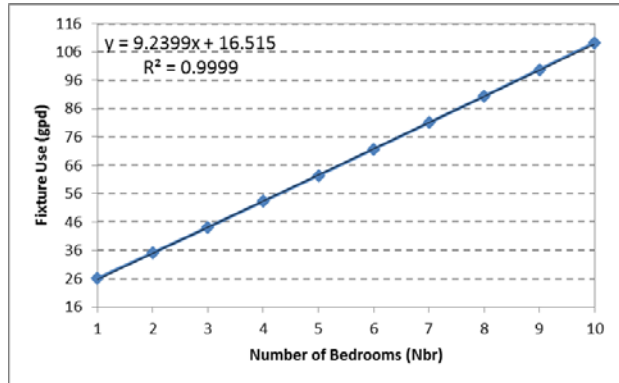

**Figure 2: Normalized fixture water use in residences where mixed water temperature is 105 °F**

As expected the data produce very good correlation coefficients, explaining almost 100% of the variance in the data.

$$nWgpd = 10.018 * Nbr^{0.3943}$$

$$nFgpd = 16.515 + 9.2399 * Nbr$$

It is now possible to rearrange the Parker and Lutz equation in terms of the number of bedrooms in a home such that total standard hot water use in the Reference Home (HWgpd) is expressed by equation 4.

$$HWgpd = CWgpd + DWgpd + F_{mix} * (nFgpd + nWgpd) \quad \text{Eq. 4}$$

### Composition of Hot Water Waste

Waste hot water stems from two principle sources: structural waste and operational waste. Structural waste comprises the residual hot water between the hot water heater and the fixtures that remains in the piping following the use of the fixture, which dissipates to the surroundings as heat loss. Operational waste occurs when, for example, a resident is waiting for a shower to get hot and gets sidetracked, often allowing a considerable amount of hot water to flow down the drain without being used. This operational waste is also often characterized by water

temperatures that are greater than the desired mixed water temperature. Sherman has analyzed detailed LBNL shower water measurement data provided by Lutz from 11 California homes (Armstrong 2014). Sherman’s analysis indicates that, for showers, the operational portion of average shower water waste is on the order of 62% of the average total shower water waste in the 11 monitored homes. Sherman also estimates that average shower total water waste (operational plus structural) constitutes approximately 15% of average total shower water use.

Examination of the data set used by Sherman in this analysis revealed that mixed shower water was measured and that segregation of the hot water portion of the shower water use was not attempted. The data set also showed that the measured structural waste portion of the shower water use was likely underestimated by a considerable amount. The average time required for showers to reach 95 °F is given as 26.35 seconds at an average shower flow rate of 1.79 gpm. Typical plumbing has a pipe diameter of ¾” and holds ~0.025 gallons per linear foot. Under these conditions, the average pipe length between the water heaters and the showers in this data set would be 28 feet under perfect flow conditions (no mixing with the cold water in the lines, no piping thermal capacitance and no heat loss). With mixing, piping capacitance and heat loss, the piping length would more likely be 25 feet or less and the “characteristic pipe length” would be 62.5% of that or 15.6 feet. This piping length is highly atypical for typical homes.

The LBNL data set includes limited information on the house profiles, giving ranges of conditioned square footage and number of stories for the homes. From these data, one can construct an estimate of the average piping length between the hot water heater and the farthest fixture (often a shower) that would be typical for these homes. Klein reports that the typical hot water piping length (PipeL) equals the length plus the width of the home footprint plus 10 feet for each floor level. This can be approximated from the conditioned square footage of the home using equation 5.

$$\text{PipeL} = 2*(\text{CFA}/\text{Nfl})^{0.5} + 10*\text{Nfl} \quad \text{Eq, 5}$$

where

CFA = conditioned floor area

Nfl = number of floors

For the LBNL data set, the median value of PipeL is 90.7 feet. This is considerably longer than the structural shower waste water measurements given in the data set indicate. Since no measurements of hot water flow and temperature were reported at the water heaters in the study, these typical piping length values are used to adjust the structural shower water waste in the LBNL data set. Klein has reported that the “characteristic pipe length” that contributes to structural waste in hot water systems is 62.5% of the typical total pipe length. Thus, the average characteristic pipe length for the cohort of homes reported in the LBNL data set would be 57 feet. Converting to gallons using ¾” pipe volume gives 1.42 gallons per shower instead of 0.7 gallons per shower as reported by the original data set. Using this median characteristic pipe length to adjust the structural waste values and using the median operational waste values from the LBNL data set, recalculating the split between operational and structural waste yields an operational waste fraction of 39.1% instead of 62%.

Henderson and Wade (2014) have reported on a complementary hot water field monitoring study of detailed hot water use in 5 homes in New York. Their results do not look at operational versus structural waste but do segregate shower use from other hot water uses. In their analyses, both Sherman (Armstrong 2014) and Henderson and Wade (2014) have used threshold hot water

temperatures at fixtures to determine when the mixed water temperature was “useful.” However, they used slightly different threshold temperatures, with Sherman using 95 °F and Henderson and Wade using 90 °F.

Henderson and Wade found that average total shower hot water waste was 10.9% of average total shower hot water use and that average total household hot water waste was 22.2% of average total household hot water use. Sherman found that average total shower hot water waste was 14.8%. Henderson and Wade provide a sensitivity analysis on threshold temperature that can be used to make an estimate from their data set of “useful” shower hot water at a threshold temperature of 95 °F. This estimate shows that the average shower hot water waste values almost exactly match (14.8% vs 14.9%). A significant difference between the two analyses is that Henderson and Wade provide data on all other hot water end uses in the homes while Sherman does not. From the Henderson and Wade data set one can determine that average shower hot water use represents 60.7% of the average total hot water use in the household but the median of the average household use is only 50.4% of the total hot water use in households. The average total household hot water waste is reported as 22.2% of the average total hot water use in the households, a value very similar to and within the range of values reported by a number of other researchers (e.g. Lutz, Klein, Van Decker).

Henderson and Wade also found that almost 69% of hot water events could not be accounted (assigned to a fixture) in their study. However, these unaccounted hot water events constituted an average of only 6.8% of average household hot water use but the median of the household averages for unaccounted events was only 3.8% of the median household hot water use. Analysis of the Henderson and Wade data shows that the average unaccounted event uses only 11.4 ounces of hot water. One can surmise from these data that the hot water was not actually intended by the user to reach the fixture. Consider for example, the single lever fixture. The lever is likely to be left in the center position most of the time, meaning that each time the fixture is accessed, hot water will flow from the storage tank whether it is desired at the fixture or not. Thus, the entire unaccounted 6.8% of total hot water use ends up being a structural waste with heat loss from the hot water piping to its surrounds.

Showers likely experience the largest operational hot water waste factor in homes due to the fact that users must wait for the shower water to get warm enough to enter. As a result, they often accomplish other tasks like tooth brushing, shaving, etc. while waiting. Other hot water uses like bathroom and kitchen sink uses usually do not experience these types of wait times prior to use. Further, machine hot water uses like dishwashers and clothes washers, which constitute about 18% of total hot water use in typical 3-bedroom homes in the typical U.S. climate, do not experience any operational hot water waste so 100% of their hot water waste is structural. Subtracting out the median value of 3.8% for unaccounted hot water waste, leaves 27.8% other uses that are not machine, shower uses or unaccounted uses. It is likely reasonable to assume that operational hot water waste from these other hot water uses is half or less than half of Sherman’s amended median shower hot water waste factor of 39.1%.

If we assume the amended median value from the LBNL data set of 39.1% for average operational waste by showers and we also assume the median values from the Henderson and Wade analysis that showers constitute 50.4% of median total household hot water use, and we further assume that the 18% machine uses have 0% operational waste and that 3.8% of median unaccounted uses are all structural waste (0% operational) and that the remaining 27.8% of hot water uses have half the operational waste fraction as showers (19.5%) we determine that the

overall household operational hot water waste fraction is about 25%. Thus, the operational hot water waste fraction used in this proposed addendum to the ANSI/RESNET 301-2014 Standard is 0.25.

### Rated Homes

For Rated Homes, Equation 4 is modified to account for both the difference between structural hot water waste and operational hot water waste and to account for changes that can be made to the standard hot water system. These changes include factors for hot water piping length, low-flow fixtures ( $\leq 2.0$  gpm for all showers and faucets), hot water piping insulation, hot water recirculation systems and Drain Water Heat Recovery (DWHR) systems. These factors are accounted through the values presented in Tables 4.2.2.5.2.11(1) through 4.2.2.5.2.11(3), which are derived from data provided by Klein (Roberts 2014), and for DWHR systems by equation 7 as provided by Van Decker (2014b).

The final equation for calculating hot water energy use in the Rated home is given by equation 6.

$$\mathbf{HWgpd = (DWgpd + CWgpd + F_{eff} * adjF_{mix} * (refFgpd + oWgpd + sWgpd * WD_{eff})) * Ndu} \quad \mathbf{Eq. 6}$$

where

$F_{eff}$  = the fixture effectiveness (standard or low-flow)

$adjF_{mix} = F_{mix}$  as adjusted for changes to the potable supply water temperature due to the installation of DWHR systems

$refFgpd$  = reference fixture hot water use

$oWgpd = refWgpd * oFrac * (1 - oCD_{eff})$

where

$oWgpd$  = daily operational hot water waste quantity

$oFrac = 0.25$  = fraction of hot water waste attributable to standard operating conditions (see above discussion)

$oCD_{eff} = 0.0$  (until specific Hot Water Operational Control Devices have been approved)

$sWgpd = (refWgpd - refWgpd * oFrac) * pRatio * sysFactor$

where

$sWgpd$  = daily structural hot water waste quantity

$refWgpd$  = reference waste hot water use

$pRatio$  = the hot water piping length ratio (rated/reference)

$sysFactor$  = the hot water piping insulation factor

$WD_{eff}$  = Water distribution system effectiveness (standard system or recirculation system)

The climate-normalization distinction is not explicitly made in equation 6 because the values representing these terms (i.e.  $Fgpd$  and  $Wgpd$ ) are always multiplied by  $F_{mix}$  (or  $adjF_{mix}$ ), which is the climate factor.

Also of interest in equation 6 is the variable ‘pRatio.’ This ratio relates the average daily quantity of residual hot water that remains in the hot water lines following use by occupants in the Rated home to that of the Reference home. The heat in this residual hot water is effectively wasted through heat loss to the piping surroundings, increasing the daily use of hot water by the occupants. Klein (Roberts 2014) reported that the best average daily value for this quantity in

existing hot water systems is 10 gallons per day. It is important to point out that these 10 gallons of wasted hot water use are included by default in the Reference Home wasted water quantity in equation 4 (i.e.  $F_{mix} * nW_{gpd}$ ).

### Drain Water Heat Recovery (DWHR) Systems

Drain Water Heat Recovery (DWHR) units are fully integrated into the hot water use (gpd) and energy consumption (kWh/y or therms/y) calculations through a water heater supply temperature adjustment resulting from the heat exchange process attendant to the DWHR system(s) installed in the residence. This adjustment results in both less hot water use and less hot water energy consumption per unit of hot water use.

Figure 3 provides a schematic diagram of the potential placements of Drain Water Heat Recovery units in a residence. Placement A heats both the supply water line to the water heater and the cold water line to the fixtures. Placement B heats only the cold water line to the fixtures and placement C heats only the supply water line to the water heater.

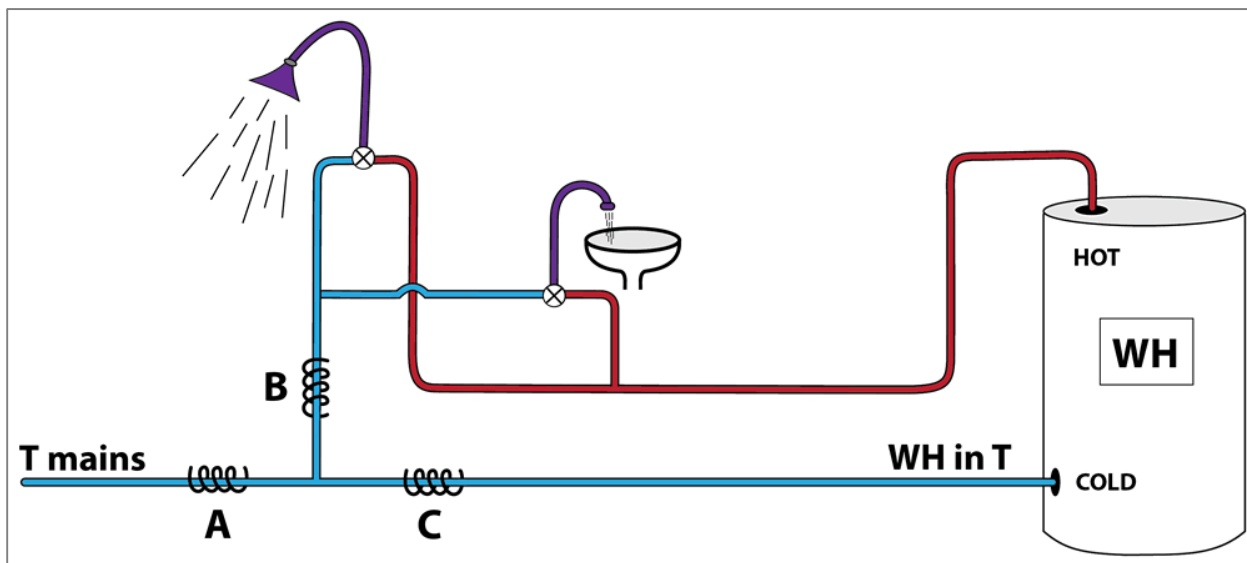

Figure 3. Schematic of Drain Water Heat Recovery unit (DWHR) placement options.

The effectiveness of the DWHR is impacted in different ways by each placement.

For placement A:

- There is a time lag between the time the shower is useful and the time that the heat exchanger fully impacts the mixed water temperature at the fixtures and there is a residual heat loss associated with the exchanged heat left in the cold water fixture piping after the shower is turned off.
- Only half of the exchanged heat is delivered to the water heater with an attendant piping line heat loss between the heat exchanger and the water heater.
- The quantity of hot water used to maintain the mixed water temperature of the fixtures ( $T_{use} = 105$  °F) is reduced by the fact that the temperature of the cold water supply to the fixture mixing valves may be significantly warmer than  $T_{mains}$  and there is significantly less piping line loss between the heat exchanger and the fixture

mixing valves than between the heat exchanger and the water heater inlet port ( $WH_{inT}$ ).

- There is a reduction in hot water use (HWgpd) proportional to the change in temperature of the cold water going to the fixture mixing valves.

For placement B:

- There is a time lag between the time the fixture is useful and the time that the heat exchanger fully impacts the mixed water temperature of the fixtures and there is a residual heat loss associated with the exchanged heat left in the cold water fixture piping after the shower is turned off.
- The quantity of hot water used to maintain the mixed water temperature of the fixtures ( $T_{use} = 105$  °F) is reduced by the fact that the temperature of the cold water supply to the fixture mixing valves may be significantly warmer than  $T_{mains}$ , however, there is no heating of the supply water going to the water heater.
- There is a reduction in hot water use (HWgpd) proportional to the change in temperature of the cold water going to the fixture mixing valves.

For placement C:

- All of the exchanged heat is delivered to the water heater with an attendant piping line heat loss between the heat exchanger and the water heater ( $WH_{inT}$ ).
- There is no heating of the fixture cold water supply lines and no attendant reduction of hot water use (HWgpd) by the fixture mixing valves.

## DWHR Calculations

Van Decker (2014) reports that drain water heat recovery units placed in locations B or C will save 77.7% as much hot water energy as drain water heat recovery units placed in location A. Van Decker (2014b) determined that the rise in potable supply water temperature to the water heater due to the drain water heat recovery unit(s) is calculated using equation 7.

$$WH_{inT_{adj}} = I_{frac} * (DWHR_{inT} - T_{mains}) * DWHR_{eff} * PLC * LocF * FixF \quad \text{Eq. 7}$$

where:

- $WH_{inT_{adj}}$  = increase in temperature of potable supply water entering water heater
- $I_{frac}$  = fractional impact of DWHR with respect to total hot water use (HWgpd)
- $DWHR_{inT}$  = 97 °F = temperature of drain water entering DWHR heat exchanger
- $T_{mains}$  = temperature of potable water supply entering residence
- $DWHR_{eff}$  = drain water heat recovery effectiveness from CSA 55B.1 (default = 46%)
- $PLC$  =  $0.0002 * pLength$  = pipe loss coefficient
- $pLength$  = piping lengths according to system type

for standard systems:

$pLength$  = pipeL as measured accordance with Section 4.1.1.5.2.11

for recirculation systems:

$pLength$  = branchL as measured in accordance with Section 4.2.2.5.2.11

$LocF$  = DWHR location factor = 1.0 for location A or 0.777 for locations B and C

$FixF$  = DWHR fixture factor, where

$FixF = 1.0$  if all of the bathing facilities in the home are connected to DWHR units



FixF = 0.5 if there are 2 or more bathing facilities in the home and only 1 is connected to a DWHR unit.

And the temperature of the potable supply water entering the water heater ( $WH_{in}T$ ) is calculated using equation 8.

$$WH_{in}T = T_{mains} + WH_{in}T_{adj} \quad \text{Eq. 8}$$

If DWHR units are installed in the residence,  $WH_{in}T$  replaces  $T_{mains}$  for the calculation of both  $F_{mix}$  and water heater energy use. This results in a reduction in both the quantity of hot water use in the residence as well as a reduction in the energy consumption per unit of water heated to the set point temperature ( $T_{set} = 125 \text{ }^\circ\text{F}$ ).

The derivation of the term ‘Ifrac’ is also of interest. As previously noted in Table 2, an Ifrac value is calculated as equal to  $0.90 * F_{gpd} / HW_{gpd}$ . This value describes the fractional impact of a DWHR unit on the total hot water use of the home. However, this relationship cannot be used directly in equation 6 because its use results in a circular mathematics problem whereby the calculation of  $adjF_{mix}$  in equation 4 is impacted by the calculation of  $WH_{in}T_{adj}$  in equation 7. Therefore, the data given in Table 2 for ‘Ifrac’ are used to develop a regression equation for Ifrac in terms of the number of bedrooms in the home. Figure 4 presents the results of this regression analysis.

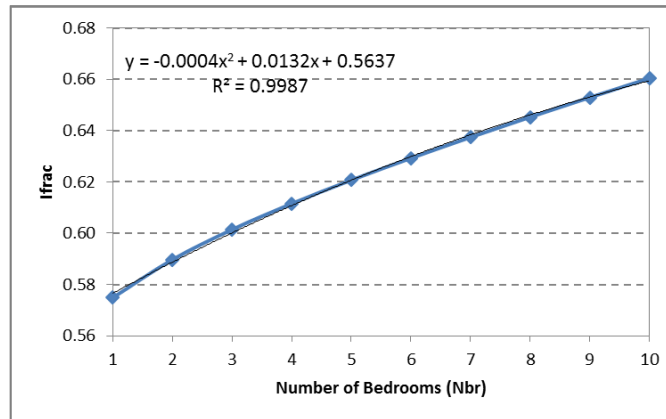

Figure 4. Regression of Ifrac against number of bedrooms

Thus, for the purposes of equation 7, Ifrac is defined as  $0.5637 + 0.0132 * Nbr - 0.0004 * Nbr^2$  rather than as  $0.90 * F_{gpd} / HW_{gpd}$ .

### Hot Water Energy Consumption

Even though hot water energy consumption (kWh/y or therms/y) is closely related to hot water quantity (gpd), the hot water distribution system impacts on hot water energy consumption are treated separately from hot water use. The provisions of Section 4.2.2.5.1.4, Section 4.2.2.5.2.11 and Section 4.2.2.5.2.11.1 of the addendum are used to determine the appropriate input quantities (gallons per day) to standard hot water energy consumption calculations, which consider only the tested EF data. Following the standard calculations of hot water energy consumption, the distribution system energy delivery effectiveness ( $ED_{eff}$ ) is used to account for the impact of the hot water distribution system.

For hot water recirculation systems, Klein (Roberts 2014) provided data for the pump energy requirements contained in Table 4.2.2.5.2.11(5) of the addendum. The values in this table are

expressed as kWh/y per watt of pump power and account for both the pump wattage and the number of hour per year the pump is expected to operate for each type of recirculation system.

Equation 4.2-15 of the addendum provides the distribution system impact on hot water energy consumption based on the hot water distribution system characteristics. For this equation it is necessary to account for the energy waste of the various distribution systems. This is accomplished through energy waste factor data ( $EW_{fact}$ ) provided by Klein (Roberts 2014) whereby the standard hot water distribution system (using 160 units of energy per year) wastes 20% (32 units of energy per year). Table 4.2.2.5.2.11(6) of the addendum provides values for  $EW_{fact}$  for each of the hot water distribution system types and piping insulation levels (Roberts 2014).

To determine the hot water distribution system  $ED_{eff}$ , the piping lengths and whether or not the waste is structural or operational must also be considered. The ratio of the hot water piping length for each system type to the hot water piping length of the reference system type is used to determine the structural component of the energy waste and the simple ratio of the operational portion of the waste (25%) is used to determine the operational component of the energy waste. The relative energy waste ( $E_{waste}$ ) of each system type is then calculated using equation 9.

$$E_{waste} = oEW_{fact} * (1-oCD_{eff}) + sEW_{fact} * pEratio \quad \text{Eq. 9}$$

where

$$oEW_{fact} = EW_{fact} * oFrac = \text{operational portion of energy waste factor}$$

where

$EW_{fact}$  is in accordance with distribution system data from Klein (Roberts 2014)

$$oFrac = 0.25$$

$oCD_{eff} = 0.0$  (a place holder until tested and approved operational hot water control device effectiveness values are available)

$sEW_{fact} = EW_{fact} - bEW_{fact} = \text{structural portion of energy waste factor}$

$pEratio = \text{piping length energy ratio}$

where

for standard system:  $pEratio = \text{PipeL} / \text{refPipeL}$

for recirculation systems:  $pEratio = \text{LoopL} / \text{refLoopL}$

and where:

$\text{PipeL} = \text{measured length of hot water piping from the hot water heater to the farthest fixture, measured from plans assuming that the hot water piping does not run diagonally and assuming 10 feet for each floor level and 5 feet for basements (if any)}$

$\text{refPipeL} = 2*(CFA/NS)^{0.5} + 10*NS + 5*Bsmnt = \text{hot water piping length for Reference Home}$

$\text{LoopL} = \text{hot water recirculation loop piping length including both supply and return sides of the loop, assuming the hot water piping does not run diagonally and assuming 10 feet for piping risers between floor levels and 5 feet between basements (if any)}$

$\text{refLoopL} = 2*\text{refPipeL} = \text{recirculation loop piping length for reference home}$

Equation 9 segregates the hot water distribution system energy waste into its structural (75%) and operational (25%) components and then applies the structural and operational effectiveness factors to each. At present, there are no approved operational hot water control devices tested

and approved for this purpose so the placeholder variable  $bCD_{eff}$  is set to zero as the default value.

### HERS Index Score Changes

A brief analysis of the impacts of the proposed addendum was accomplished to answer the question: “How much will the HERS Index score change as a result of this change in the way hot water systems are treated in the Standard?” The analysis examined 2,400 ft<sup>2</sup>, 2-story, 3-bedroom homes on crawlspace foundations with three different gas water heater efficiencies (EF=0.53, EF=0.59 and EF=0.67) in three different climates.

Three home efficiency scenarios were considered:

- Scenario 1: IECC 2012 compliant homes with minimum standard HVAC equipment
- Scenario 2: HERS Reference Homes
- Scenario 3: Typical existing homes

Each home efficiency scenario was examined in three different climates:

- Duluth, MN – a cold climate with high heating loads, low cooling loads and high water heating loads
- San Francisco, CA – a mild marine climate with moderate heating loads, low cooling loads and typical water heating loads
- Miami, FL – a hot climate with low heating loads, high cooling loads and low water heating loads

Results of the analysis are presented in Table 4. As expected, the relatively mild climate of San Francisco shows the largest sensitivity to the change in water heating calculation methods. This is due to the fact that water heating is a larger percentage of the total Reference Home load in San Francisco (14.5%) than in Duluth (9.5%) or Miami (4.0%).

**Table 4: Change HERS Index Scores for 3 home scenarios in 3 climates with 3 WH efficiencies**

Scenarios	gas WH EF	Duluth			San Francisco			Miami		
		Old	New	Δ HERS	Old	New	Δ HERS	Old	New	Δ HERS
Scenario 1	0.53	68.63	67.84	-0.79	73.50	71.73	-1.77	70.54	69.32	-1.22
	0.59	65.56	65.09	-0.46	68.84	67.83	-1.01	68.78	68.13	-0.65
	0.67	62.41	62.28	-0.13	64.08	63.84	-0.24	67.00	66.92	-0.08
	range	6.22	5.56	0.67	9.41	7.88	1.53	3.55	2.40	1.14
Scenario 2	0.53	103.10	102.77	-0.33	104.71	103.94	-0.76	101.78	101.20	-0.57
	0.59	100.00	100.00	0.00	100.00	100.00	0.00	100.00	100.00	0.00
	0.67	96.81	97.15	0.34	95.18	95.97	0.78	98.18	98.77	0.59
	range	6.29	5.62	0.67	9.52	7.98	1.55	3.59	2.44	1.16
Scenario 3	0.53	130.20	130.26	0.06	130.85	131.01	0.16	130.77	130.86	0.09
	0.59	127.10	127.50	0.39	126.15	127.07	0.92	128.99	129.66	0.66
	0.67	123.91	124.65	0.73	121.32	123.03	1.71	127.18	128.42	1.25
	range	6.29	5.62	0.67	9.52	7.98	1.55	3.59	2.44	1.16

The HERS Index score for the highlighted cases is 100 by definition

The range of HERS Index scores indicates the relative impact of water heater efficiency changes in each climate. This range is largest in San Francisco and smallest in Miami. The relatively small range of HERS Index scores in Miami (relatively smaller sensitivity to water heater efficiency) is due to the fact that the potable water supply temperature is high in Miami compared with the other two climates. The change in range across home efficiency scenarios is relatively consistent within each climate, indicating that neither the old nor the new hot water heating calculation method is particularly sensitive to home energy efficiency. The range change ( $\Delta$  HERS) is greatest in San Francisco and smallest in Duluth, indicating again that San Francisco's water heating load is a significantly larger percentage of its total load and that space heating loads in Duluth are large enough to mask changes in water heater efficiency changes.

## References

- ANSI/RESNET 301 (2014) "Standard for the Calculation and Labeling of the Energy Performance of Low-Rise Residential Buildings using the HERS Index." Residential Energy Services Network, Inc., Oceanside, CA.
- Armstrong, S. (2014) e-mail with attachment from J. Lutz, "Re: Fwd: New Data," 3:11 a.m., April 21, 2014
- Henderson, H and J. Wade (2014) "Disaggregating Hot Water use and Predicting Distribution Losses in Five Test Homes." U.S. DOE Building America Program Final Report proof, ARIES Collaborative, NY, New York
- Hendron, R. (2008) "Building America Research Benchmark Definition." NREL/TP-550-42662, National Renewable Energy Laboratory, Golden, CO.
- Lutz, J and M. Melody (2012) "Typical Hot Water Draw Patterns Based on Field Data." Environmental Energy Technologies Division, Lawrence Berkeley National Laboratory, Berkeley, CA.
- Klein, G. (2014) e-mail, "Re: Equations for determination of E<sub>Def</sub>," 7:37 p.m., March 3, 2014.
- Parker, D. (2014) e-mail, "Re: Hot Water Waste Quantity: Hot Water Set Temperatures." 4:39 p.m., April 24, 2014.
- Parker, D. and J. Lutz (2014) "Estimating Daily Domestic Hot Water Use in North American Homes." Draft research paper in publication, Florida Solar Energy Center, Cocoa, FL.
- Roberts, D. (2014) e-mail with attachment from G. Klein, "Re: SDC Meeting Monday 12 ET," 9:37 a.m., March 3, 2014
- Sherman, T (2014) e-mail, "Re: Structural Waste Data" 10:27 p.m., May 19, 2014.
- Van Decker, G. (2014) Conference call between G. Van Decker, G. Klein, R. Salcido and P. Fairey, March 13, 2014.
- Van Decker, G. (2014a) e-mail, "Re: Pipe Lengths," 4:06 p.m., March 21, 2014.
- Van Decker, G. (2014b) e-mail, "Re: Revised CMP models of Hot Water," 3:51 p.m., March 24, 2014.